

# S3220E/S3226E

## ELECTRIC SLAB SCISSOR LIFTS



- Self-propelled electric scissor lifts
- Compact & robust
- Roll-out extension decks for extra reach
- Suitable for indoor and outdoor use (S3220E)
- Ideal for construction & maintenance applications



# S3220E/S3226E

DIMENSIONS	S3220E	S3226E
Max. working height	8.1m	9.9m
Max. platform height (A)	6.1m	7.9m
Platform size (stowed)	0.72m x 2.14m	0.72m x 2.14m
Platform size (extended)	0.72m x 2.6m	0.72m x 2.6m
Extension deck length (B)	0.91m	0.91m
Overall length (with step) (D)	2.3m	2.3m
Overall length (without step)	2.26m	2.26m
Overall width (C)	0.81m	0.81m
Stowed height (E)	2.17m	2.3m
Min. height (guardrails folded)	1.72m	1.85m
Ground clearance (stowed)	95mm	95mm
Ground clearance (elevated)	19mm	19mm

PERFORMANCE		
Platform capacity	409kg	250kg
Max. drive height	6.1m	7.9m
Max. wind speed	12.5m/s	0m/s
Max. drive speed (stowed)	3.2km/h	3.2km/h
Max. drive speed (elevated)	0.6km/h	0.6km/h
Raise/lower time	34/43 sec	50/56 sec
Gradeability	25%	25%
Inside turning radius	0.76m	0.76m
Outside turning radius	2.36m	2.36m
Tyres	15 x 4 non-marking rubber	
Controls	proportional	
Drive system	2-wheel drive	

POWER	
Power source	24V DC battery electric
Charger	90 - 240V, 25amp

WEIGHT		
Weight	2,045kg	2,268kg

## TURNING RADIUS

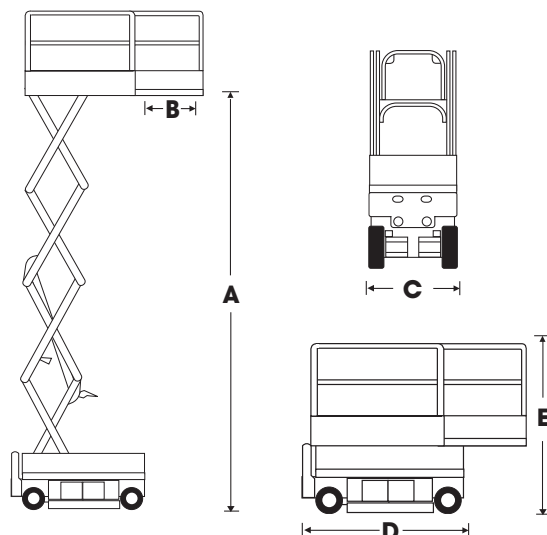
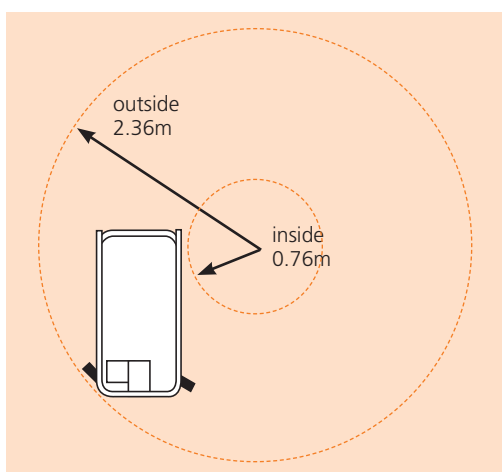

## STANDARD FEATURES

- Roll-out deck extension with dual locks
- Non-marking tyres
- Loading control pendant
- Swing-out service trays
- Saloon-door style entry gates
- Descent alarm
- All motion alarm
- 2 persons indoor
- 1 person outdoor (S3220E)
- Proportional controls, including descent
- Power line to platform
- Hour meter & on-board diagnostics display
- Integrated battery charger
- Battery condition indicator
- Crane & forklift points
- Dual lanyard attachments points
- Flashing amber light
- Scissor stack roller slide plates (set of 2)
- 2 year parts & labour, 5 year structural warranty
- CE approved

## OPTIONS

- Special paint colours
- Snorkel Guard™ secondary guarding system
- Snorkel OnSite™ telematics
- Environmental hydraulic oil
- Airline to platform
- Aircraft bumpguard package
- Panel carrier (S3220E)
- Top rail