

Genie® GS™ -1432m & GS-1932m

Specifications CE, UKCA

Models	GS-1432m		GS-1932m	
Measurements	US	Metric	US	Metric
Working height max. - indoor ⁽¹⁾	20 ft 1 in	6.30 m	24 ft 2 in	7.55 m
Working height max. - outdoor ⁽¹⁾	18 ft	5.66 m	21 ft	6.57 m
A Platform height max. - indoor	14 ft 1 in	4.30 m	18 ft 3 in	5.55 m
A Platform height max. - outdoor	12 ft	3.66 m	15 ft	4.57 m
B Platform height - stowed	2 ft 6 in	0.77 m	2 ft 10 in	0.87 m
C Platform length - outside	4 ft 7 in	1.40 m	4 ft 7 in	1.40 m
C Platform length - outside, extended	6 ft 7 in	2.00 m	6 ft 7 in	2.00 m
Slide-out platform extension deck - length	2 ft	0.60 m	2 ft	0.60 m
D Platform width - outside	2 ft 6.5 in	0.78 m	2 ft 6.5 in	0.78 m
Guardrail height	3 ft 7 in	1.10 m	3 ft 7 in	1.10 m
Toeboard height	6 in	15 cm	6 in	15 cm
E Machine Height - stowed (fixed rails)	6 ft 2 in	1.88 m	6 ft 5 in	1.97 m
F Length machine - stowed	4 ft 7 in	1.40 m	4 ft 7 in	1.40 m
F Length machine - stowed, extended	6 ft 7 in	2.00 m	6 ft 7 in	2.00 m
G Width	32 in	0.81 m	32 in	0.81 m
H Wheelbase	3 ft 8 in	1.12 m	3 ft 8 in	1.12 m
I Ground clearance (center) - pothole guards retracted	2.8 in	7 cm	2.8 in	7 cm
I Ground clearance - pothole guards deployed	0.75 in	1.90 cm	0.75 in	1.90 cm

Productivity

Max. platform occupancy (in/out)	2/1		2/1	
Lift capacity	500 lb	227 kg	500 lb	227 kg
Lift capacity - extension deck extended	250 lb	113 kg	250 lb	113 kg
Max. platform drive height	14 ft 1 in	4.30 m	18 ft 2 in	5.55 m
Drive speed - stowed	2.5 mph	4.0 km/h	2.5 mph	4.0 km/h
Drive speed - raised	0.5 mph	0.8 km/h	0.5 mph	0.8 km/h
Gradeability - stowed ⁽²⁾	25%/14°		25%/14°	
Turning radius - inside/outside	0/4 ft 6 in	0/1.37 m	0/4 ft 6 in	0/1.37 m
Lifting speed - raise/lower	19/20 sec		26/20 sec	
Tilt sensor activation (front to back/side to side)	3° / 1.5°		3° / 1.5°	
Tires - solid non-marking	10×3 in	25.4×7.62 cm	10×3 in	25.4×7.62 cm

Power

Power	24V DC (2×12V 115Ah)	24V DC (2×12V 115Ah)
Hydraulic tank capacity (E-Drive)	1.5 gal	5.7L

Weight⁽³⁾ and Floor Loading⁽⁴⁾

Weight	1,985 lb	900 kg	2,600 lb	1,179 kg
Weight max. (adding all possible options)	2,064 lb	936 kg	2,680 lb	1,216 kg
Tire load max.	937 lb	425 kg	1257 lb	570 kg
Tire contact pressure	143 psi	988 kPa	164 psi	1,133 kPa
Occupied floor pressure	203 psf	9.73 kPa	254 psf	12.14 kPa

Sound and Vibration Levels

Sound Pressure level (ground workstation)	< 70 dBA		< 70 dBA	
Sound Pressure level (platform workstation)	< 70 dBA		< 70 dBA	
Vibrations	< 8 ft 2 in/s ²	< 2.5 m/s ²	< 8 ft 2 in/s ²	< 2.5 m/s ²

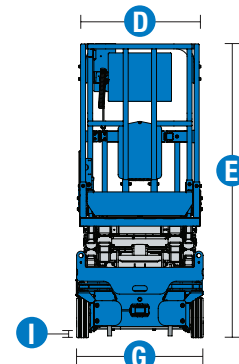
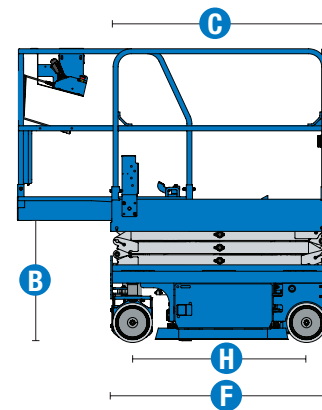
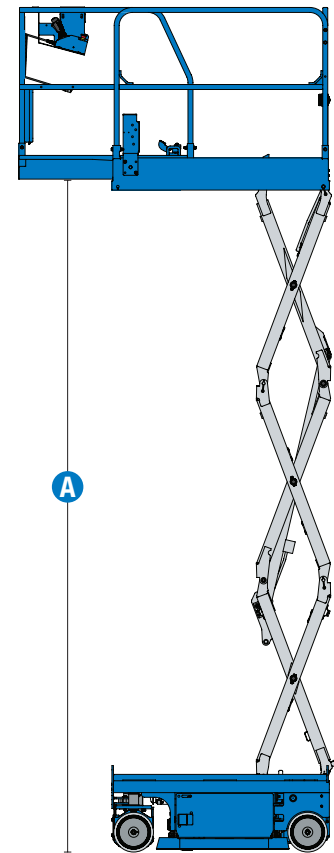

Electric Slab Scissor Lifts

Genie® GS™ -1432m & GS-1932m

SKU: Standard Model

CE, UKCA

- **GS1432M1CE0003:** GS-1432m, E-Drive, 110V
- **GS1432M1CE0004:** GS-1432m, E-Drive, 220V

SKU: Standard Model

- **GS1932M1CE0003:** GS-1932m, E-Drive, 110V
- **GS1932M1CE0004:** GS-1932m, E-Drive, 220V

* Build to Order

Option availability		S	S+	BtO
Power	Standard FLA flooded lead acid batteries	✓	✓	✓
	AGM Maintenance-free batteries			○
	Rear recessed charger receptacle	✓	✓	✓
Platform	Fixed rails, Half-height swing gate	✓	✓	✓
	Folding rails, Half-height swing gate			○
	Slide out extension deck	✓	✓	✓
	Power to platform, no RCBO	✓	✓	✓
	Power to platform with RCBO		○	○
	Air line to platform			○
	Automotive-style horn		○	○
	AC power to platform	✓	✓	✓
	Descent, tilt and motion alarm	✓	✓	✓
	Diamond plate platform deck	✓	✓	✓
	Dual LED flashing beacons	✓	✓	✓
	Electric horn	✓	✓	✓
	Lanyard attachment points	✓	✓	✓
	Platform control guard (PCON)	✓	✓	✓
	Platform load sense system	✓	✓	✓
	Proportional drive and lift	✓	✓	✓
	SmartLink dual zone control system	✓	✓	✓
	Chassis	Lift Connect Telematics		○
Lift Connect with Access Manager upgrade			○	○
Eco32 biodegradable hydraulic oil			○	○
Lift Guard White Noise Alarm			○	○
Lift Tools Spill Guard (E-Drive)				○
Auxiliary platform lowering		✓	✓	✓
Driveable at full height		✓	✓	✓
Dual front wheel electric brakes		✓	✓	✓
Dual front wheel sealed AC electric drive motors (E-Drive)		✓	✓	✓
Electric brake release (E-Drive)		✓	✓	✓
On board diagnostic system with battery charge indicator		✓	✓	✓
Pothole protection		✓	✓	✓
Rear fork pockets		✓	✓	✓
Solid non-marking tires		✓	✓	✓
Tech Pro Link connector		✓	✓	✓
Tie-down and lifting points	✓	✓	✓	

- S Standard
- S+ Standard +
- BtO Build to Order
- ✓ Standard Features
- Options



Compact Footprint



Lightweight



E-Drive

