

A38E

ELECTRIC ARTICULATED BOOM LIFT



- Popular electric articulated boom lift
- Lightweight, durable and reliable
- Smooth, easy to use controls
- Compact chassis for excellent maneuverability
- Suitable for indoor and outdoor use



snorkelTM

www.snorkellifts.com



A38E

DIMENSIONS	A38E
Max. working height	13.5m
Max. platform height (A)	11.5m
Max. working outreach	6.1m
Clearance height at max. outreach	5.4m
Platform size (E x F)	0.69m x 1.11m
Overall width (B)	1.5m
Overall length (C)	4.1m
Stowed height (D)	2.0m
Ground clearance	120mm

PERFORMANCE	
Platform capacity (SWL)	215kg
Max. drive height	11.5m
Max. wind speed	12.5m/s
Max. drive speed (stowed)	4.0km/h
Max. drive speed (elevated)	0.65km/h
Platform rotation	90° (+45°/-45°)
Turret rotation (non-continuous)	360°
Tailswing (riser boom elevated)	0m
Tailswing (riser boom stowed)	1.4m
Raise/lower time	83/68 sec
Gradeability	36%
Inside turning radius	1.12m
Outside turning radius	2.4m
Tires	22 x 9 16 non-marking rubber
Controls	proportional
Drive system	direct drive DC

POWER	
Power source	8 x 6V, 220Ah batteries
Battery charger	100-200V/15A

WEIGHT	
Weight	3,880kg

WORKING ENVELOPE

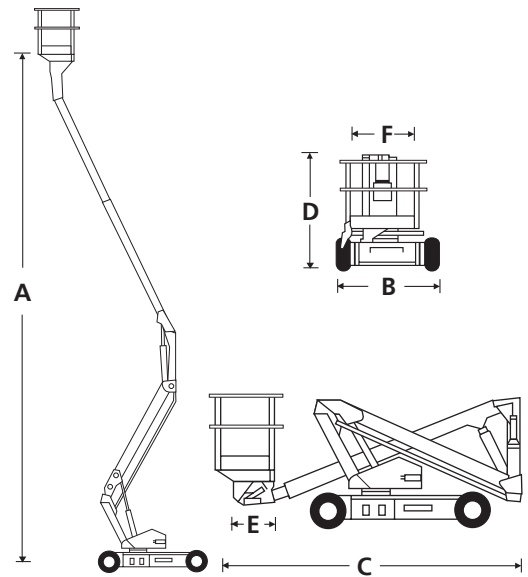
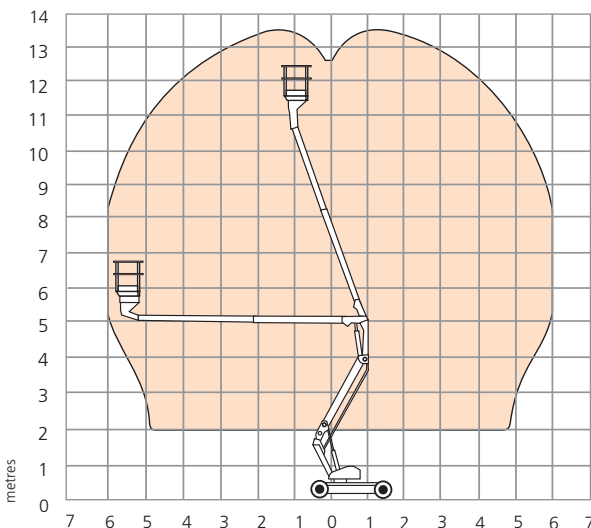

STANDARD FEATURES

- Snorkel Guard™ secondary guarding system
- Proportional controls
- Hydraulic platform rotation
- Minimal front boom overhang
- Ultra-tight inside turning radius
- Power line to platform
- Platform overload system
- 3.5° tilt alarm
- Direct DC drive
- Non-marking tires
- Hour meter & on-board diagnostics display
- Integrated battery charger 90-240V 25A 50/60Hz
- Flashing amber light
- Horn
- Drive motion alarm
- 2 year parts & labor, 5 year structural warranty
- ANSI compliant

OPTIONS

- Special paint colors
- Environmental hydraulic oil
- Snorkel OnSite™ telematics

snorkel

CHERRYPICKER·IE

