

## Nifty 120T | 12.2m Trailer Mount

### KEY FEATURES

Working Height: 12.2m (40ft)

Working Outreach : 6.1m (20ft)

Telescopic Upper Boom

Greater accuracy when positioning platform

Bi-Energy Available

Optimising utilisation

Hydraulic Outriggers

For quick & easy setup

Fully Proportional Hydraulic Controls

Simple, reliable & easy to maintain

Telescopic Axles

Access through double doorway openings#

Traction Drive Option

Improved manoeuvrability on site.



Distributed By

**CHERRYPICKER**   
Ireland's Leading Supplier of Access Platforms



cherrypicker.ie



sales@cherrypicker.ie



353 (1) 835 4788



353 87 255 7755



The Nifty 120T trailer mount is specifically designed to give maximum reach performance from the most compact chassis possible.

By utilising its versatile telescopic upper boom, the Nifty 120T trailer mount delivers unrivalled working outreach, especially at lower levels where it's needed most.

Hydraulically operated outriggers make setting up the Nifty 120T trailer mount both quick and easy.

Telescopic axles coupled with a very compact base make the Nifty 120T trailer mount one of the most compact and manoeuvrable trailer mounts available.

The Nifty 120T trailer mount is also available with a [traction drive](#) option that offers a simple, cost effective and safe method for on-site positioning.



Working Height (A) 12.2m (40ft)



Platform Height (B) 10.2m (33ft 6in)



Machine Length (J) 4.5m (14ft 9in)



Machine Width (F) 1.5m (4ft 11in)



Safe Working Load 200kg (440lbs)



Machine Height (D) 1.9m (6ft 3in)



Minimum Weight 1400kg (3100lbs)



Cage Size 1.1m x 0.65m  
(3ft 7in x 2ft 2in)



Traction Drive Available



Outrigger Type Hydraulic



Retracted Width (E) 1.1m (3ft 7in)



Working Outreach (C) 6.1m (20ft)



Working Width (G) 3.55m (11ft 8in)

Distributed By



cherrypicker.ie



353 (1) 835 4788



sales@cherrypicker.ie



353 87 255 7755



Power Options

- Mains Only
- Battery Only
- Petrol or Diesel Only
- Bi-Energy (Engine & Battery)

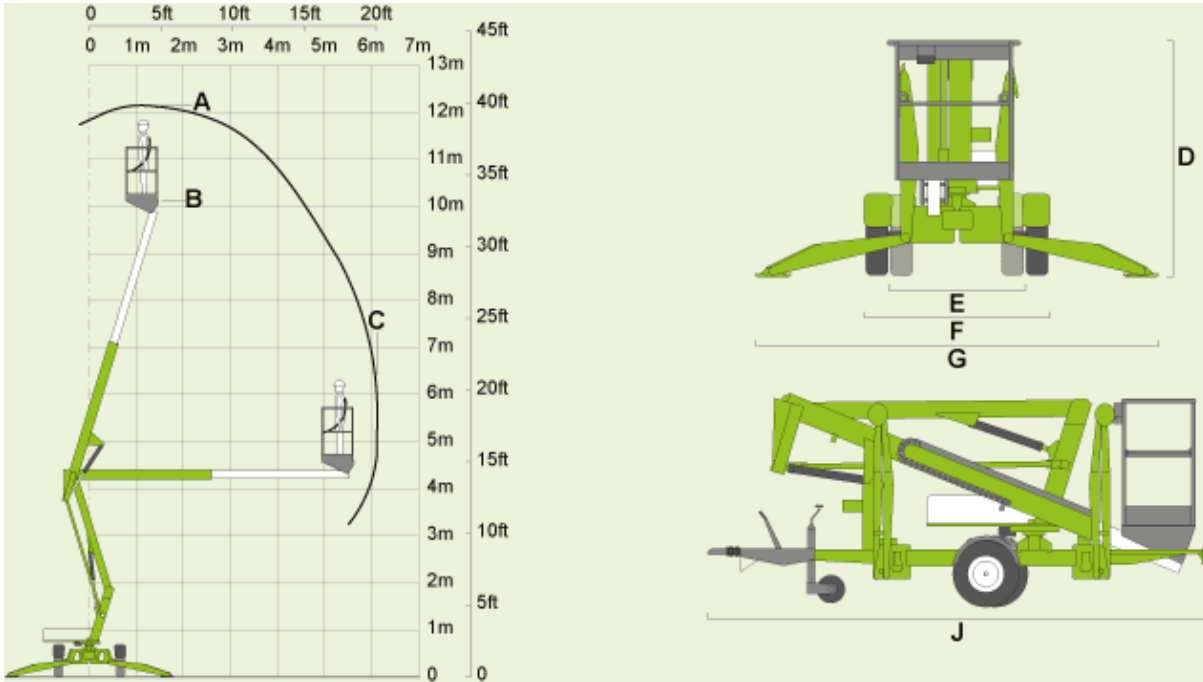

Distributed By



[cherrypicker.ie](http://cherrypicker.ie)



[sales@cherrypicker.ie](mailto:sales@cherrypicker.ie)



353 (1) 835 4788



353 87 255 7755