



HA12 IP

Excellent manoeuvrability in the tightest spaces

- Compact size with 1.35 m width
- 2m stowed height can pass through a standard doorway
- 140° (+70°/-70°) fly jib range of motion
- Tight turning radius (2.85 m)

Optimal productivity and comfort

- 6.6 m outreach
- Long working cycles
- Full proportional controls

Robust, reliable and easy to maintain



Haulotte 
GROUP

More than lifting





HA12 IP



ELECTRIC ARTICULATING BOOMS

TECHNICAL DATA

HA12 IP

Working height	12 m
Platform height	10 m
Horizontal outreach	6.6 m
Up and over clearance	5.25 m
Lift capacity	230 kg
Vertical jib rotation	140° (+70/-70)
A Length	5.45 m
B Width	1.35 m
C Height - stowed	2 m
Height - transport	2.5 m
D Wheelbase	2 m
E Ground clearance	15 cm
F x G Platform size	1.2 x 0.8 m
Tailswing	0 cm
Proportional drive speed	0.9 - 4.5 km/h
Turning radius - outside	2.85 m
Turntable rotation	355 °
Platform rotation	180° (+90/-90)
Energy	48 V - 345 Amph (C5)
Gradeability	25 %
Tyres - non marking	7x12"
Hydraulic system capacity	30 l
Weight	5900 kg

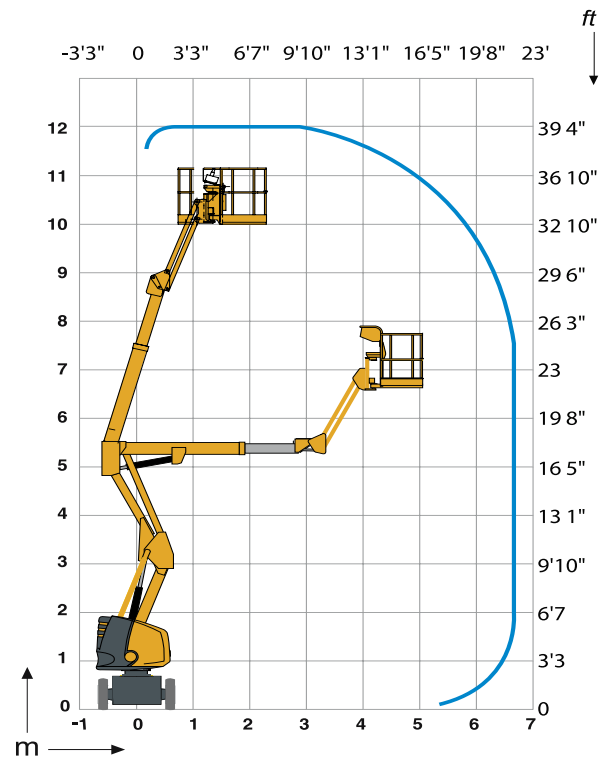

STANDARD EQUIPMENT

- Semi-traction battery
- Battery charge indicator
- 48 V – 50 A battery charger
- Sensitive control box
- 3° Tilt alarm
- Non marking tyres
- Outside / inside use: wind rated to 45 km/h
- Brake release
- Hourmeter
- Slewing block pin
- Towing hooks and lifting eyes
- Emergency hand pump
- 2 wheel drive and steer
- Load limiter in cage
- Horn

OPTIONS AND ACCESSORIES

- Flashing light
- Power to platform
- Travel alarm
- Centralised battery filling
- 360 Ah traction batteries
- Waterproof batteries
- Air line to cage
- Electric remote brake release
- Biodegradable oil
- Large basket option (1,5m x 0,8m)

