

Genie® GS™ -4655

Specifications

ANSI A92.20, CSA B354.6

CHERRY PICKER·IE

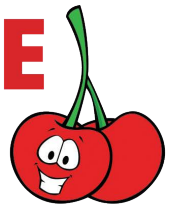

Models	GS-4655	
Measurements	US	Metric
Working height max. - indoor ⁽¹⁾	51 ft 9 in	15.95 m
Working height max. - outdoor ⁽¹⁾	27 ft 6 in	8.55 m
A Platform height max. - indoor	45 ft 9 in	13.95 m
A Platform height max. - outdoor	21 ft 6 in	6.55 m
B Platform height - stowed	5 ft 5 in	1.64 m
C Platform length - outside	9 ft 4 in	2.84 m
C Platform length - outside, extended	13 ft 4 in	4.10 m
Slide-out platform extension deck - length	4 ft	1.22 m
D Platform width - outside	4 ft 5 in	1.35 m
Guardrail height	3 ft 7.3 in	1.10 m
Toeboard height	6 in	15 cm
E Machine Height - stowed (folding rails)	9 ft 1 in	2.77 m
Machine Height - stowed (rails lowered)	6 ft 6 in	1.98 m
F Length machine - stowed	10 ft 2 in	3.11 m
F Length machine - stowed, extended	14 ft 2 in	4.33 m
G Width	4 ft 7 in	1.40 m
H Wheelbase	8 ft 1 in	2.47 m
I Ground clearance (center) - pothole guards retracted	5.9 in	15 cm
I Ground clearance - pothole guards deployed	0.75 in	2 cm

Productivity

Max. platform occupancy (in/out)	3/2	
Lift capacity	770 lb	350 kg
Lift capacity - extension deck extended	300 lb	136 kg
Max. platform drive height	45 ft 9 in	13.95 m
Drive speed - stowed	2.5 mph	4.0 km/h
Drive speed - raised	0.5 mph	0.8 km/h
Gradeability - stowed ⁽²⁾	25%	
Turning radius - inside/outside	12 in/10 ft	31 cm/3.05 m
Lifting speed - raise/lower	92/58 sec	
Tilt sensor activation (front to back/side to side)	3° / 1.5°	
Tires - solid non-marking	15x5 in	38x13 cm

Power

Power	24V DC (4x12V 300Ah)	
Hydraulic tank capacity (E-Drive)	7.5 gal	28.4 L

Weight⁽³⁾ and Floor Loading⁽⁴⁾

Weight	8,160 lb	3,701 kg
Weight max. (adding all possible options)	8,160 lb	3,701 kg
Tire load max.	3,682 lb	1,670 kg
Tire contact pressure	210 psi	1,451 kPa
Occupied floor pressure	205 psf	9.81 kPa

Sound and Vibration Levels

Sound Pressure level (ground workstation)	< 70 dBA	
Sound Pressure level (platform workstation)	< 70 dBA	
Vibrations	< 8 ft 2 in/s ²	< 2.5 m/s ²

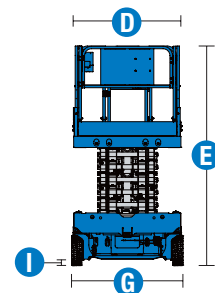
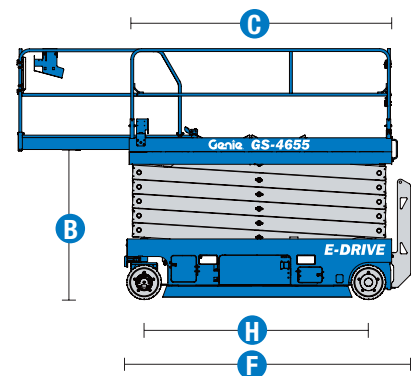
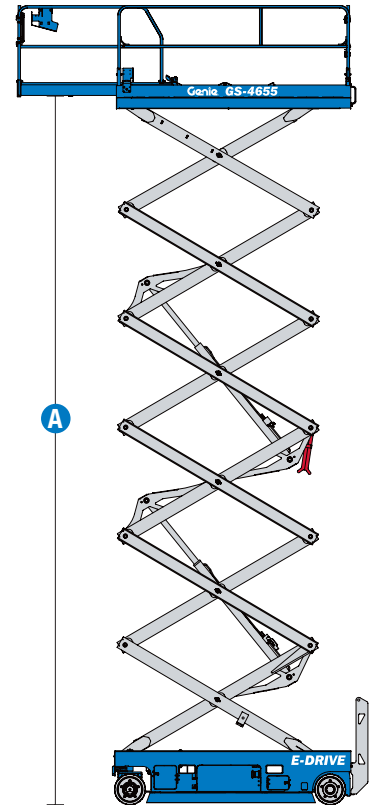

CHERRY PICKER·IE

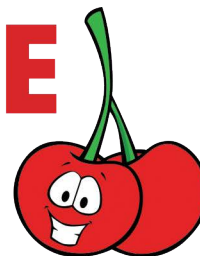

Genie® GS™ -4655

SKU: Standard Model ANSI A92.20, CSA B354.6

- **GS4655E1AE0002:** GS-4655, E-Drive

* Build to Order

Option availability	S	S+	BtO
Power			
Standard FLA flooded lead acid batteries	✓	✓	✓
AGM Maintenance-free batteries		○	○
Drive cut-out while charging		○	○
Power Inverter		○	○
Rear recessed charger receptacle	✓	✓	✓
Platform			
Folding rails, Full-height swing gate	✓	✓	✓
Slide out extension deck	✓	✓	✓
Air line to platform			○
Automotive-style horn		○	○
AC power to platform	✓	✓	✓
Descent, tilt and motion alarm	✓	✓	✓
Diamond plate platform deck	✓	✓	✓
Dual LED flashing beacons	✓	✓	✓
Electric horn	✓	✓	✓
Lanyard attachment points	✓	✓	✓
Platform control guard (PCON)	✓	✓	✓
Platform load sense system	✓	✓	✓
Proportional drive and lift	✓	✓	✓
SmartLink dual zone control system	✓	✓	✓
Chassis			
Lift Connect Telematics		○	○
Lift Connect with Access Manager upgrade		○	○
Lift Guard White Noise Alarm		○	○
Auxiliary platform lowering	✓	✓	✓
Driveable at full height	✓	✓	✓
Dual front wheel sealed AC electric drive motors (E-Drive)	✓	✓	✓
Electric brake release (E-Drive)	✓	✓	✓
On board diagnostic system with battery charge indicator	✓	✓	✓
Pothole protection	✓	✓	✓
Side and rear fork pockets	✓	✓	✓
Solid non-marking tires	✓	✓	✓
Tech Pro Link connector	✓	✓	✓
Tie-down and lifting points	✓	✓	✓

- S Standard
- S+ Standard +
- BtO Build to Order
- ✓ Standard Features
- Options



Indoor & Outdoor Use



Max. Lift Capacity



E-Drive

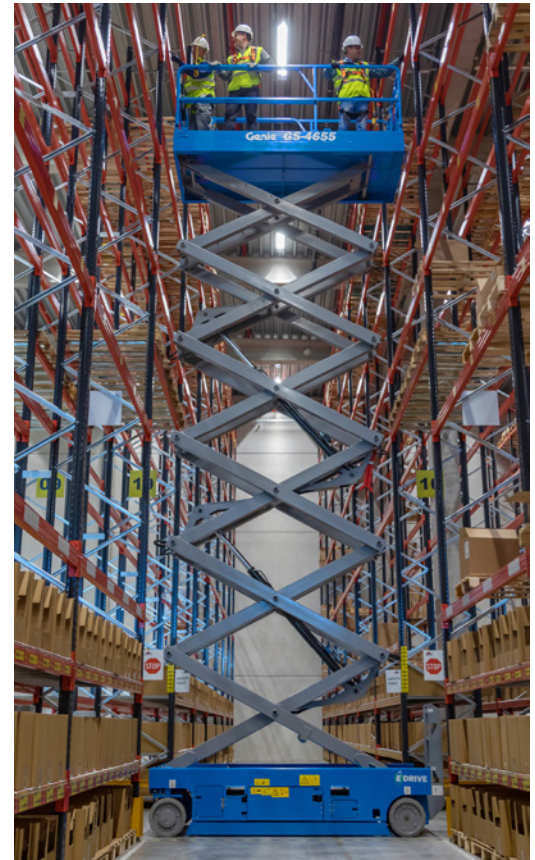

CHERRY PICKER·IE



Sales & Service



Bespoke Design



MEWP Training



Handling Solutions

