

Genie® GS™ -3232 & GS-3246

Specifications

ANSI A92.20, CSA B354.6

Models	GS-3232		GS-3246	
Measurements	US	Metric	US	Metric
Working height max. - indoor ⁽¹⁾	38 ft 1 in	11.78 m	38 ft 1 in	11.78 m
Working height max. - outdoor ⁽¹⁾	24 ft	7.49 m	28 ft	8.71 m
A Platform height max. - indoor	32 ft 1 in	9.78 m	32 ft 1 in	9.78 m
A Platform height max. - outdoor	18 ft	5.49 m	22 ft	6.71 m
B Platform height - stowed	4 ft 4 in	1.32 m	4 ft 4 in	1.32 m
C Platform length - outside	7 ft 5 in	2.26 m	7 ft 5 in	2.26 m
C Platform length - outside, extended	10 ft 5 in	3.18 m	10 ft 5 in	3.18 m
Slide-out platform extension deck - length	3 ft	0.91 m	3 ft	0.91 m
D Platform width - outside	32.9 in	0.84 m	3 ft 10 in	1.18 m
Guardrail height	3 ft 7 in	1.10 m	3 ft 7 in	1.10 m
Toeboard height	6 in	15 cm	6 in	15 cm
E Machine Height - stowed (folding rails)	8 ft	2.44 m	8 ft	2.44 m
Machine Height - stowed (rails lowered)	6 ft 10 in	2.08 m	6 ft	1.83 m
F Length machine - stowed	8 ft	2.44 m	8 ft	2.44 m
F Length machine - stowed, extended	10 ft 11 in	3.33 m	10 ft 11 in	3.33 m
G Width	32.2 in	0.82 m	3 ft 10 in	1.18 m
H Wheelbase	6 ft 1 in	1.85 m	6 ft 1 in	1.85 m
I Ground clearance (center) - pothole guards retracted	5 in	12 cm	5 in	12 cm
I Ground clearance - pothole guards deployed	0.9 in	2.30 cm	0.9 in	2.30 cm

Productivity

Max. platform occupancy (in/out)	2/1		2/1	
Lift capacity	500 lb	227 kg	700 lb	318 kg
Lift capacity - extension deck extended	250 lb	113 kg	250 lb	113 kg
Max. platform drive height	20 ft	6.71 m	32 ft 1 in	9.78 m
Drive speed - stowed	2.0 mph	3.2 km/h	2.0 mph	3.2 km/h
Drive speed - raised	0.5 mph	0.8 km/h	0.5 mph	0.8 km/h
Gradeability - stowed ⁽²⁾	25%		25%	
Turning radius - inside/outside	0/7 ft	0/2.13 m	0/7 ft 6 in	0/2.29 m
Lifting speed - raise/lower	58/32 sec		53/34 sec	
Tilt sensor activation (front to back/side to side)	3° / 1.5°		3° / 1.5°	
Max. outrigger leveling (front to back/side to side)	2° / 5°		-	
Tires - solid non-marking	15x5 in	38x13 cm	15x5 in	38x13 cm

Power

Power - FLA	24V DC (4x6V 210Ah)	24V DC (4x6V 210Ah)
Power - Lithium-Ion	24V DC (1x24V 90Ah)	24V DC (1x24V 90Ah)
Hydraulic tank capacity (E-Drive)	4 gal	15 L

Weight(3) and Floor Loading⁽⁴⁾

Weight	5,367 lb	2,434 kg	5,218 lb	2,367 kg
Weight max. (adding all possible options)	5,537 lb	2,512 kg	5,379 lb	2,440 kg
Tire load max.	1,909 lb	866 kg	2,227 lb	1,010 kg
Tire contact pressure	125 psi	864 kPa	146 psi	1,021 kPa
Occupied floor pressure	307 psf	14.72 kPa	210 psf	10.23 kPa

Sound and Vibration Levels

Sound Pressure level (ground workstation)	< 70 dBA	< 70 dBA
Sound Pressure level (platform workstation)	< 70 dBA	< 70 dBA
Vibrations	< 8 ft 2 in/s ²	< 2.5 m/s ²

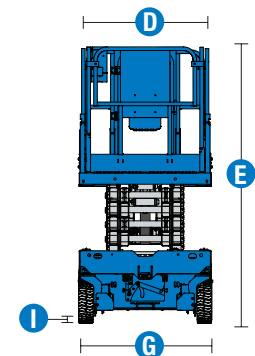
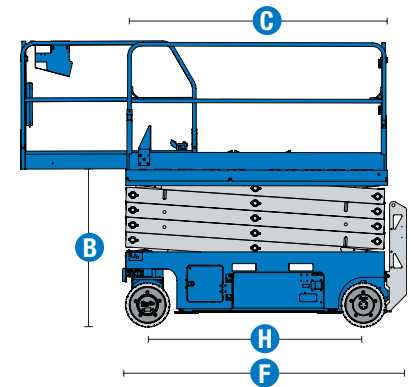
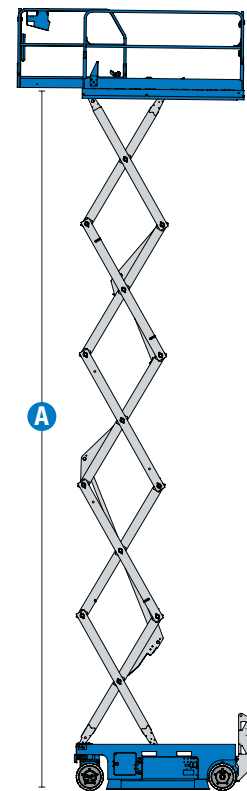

Genie® GS™ -3232 & GS-3246

SKU: Standard Model

- **GS323201AE0004:** GS-3232, E-Drive

SKU: Standard Model

- **GS324601AE0002:** GS-3246, E-Drive

* Build to Order

Option availability	S	S+	BtO
Power			
Standard FLA flooded lead acid batteries	✓	✓	✓
AGM Maintenance-free batteries		○	○
Lithium-Ion battery			○
Drive cut-out while charging		○	○
Power Inverter		○	○
Rear recessed charger receptacle	✓	✓	✓
Platform			
Folding rails, Full-height swing gate (GS-3246)	✓	✓	✓
Folding rails, Half-height swing gate (GS-3232)	✓	✓	✓
Slide out extension deck	✓	✓	✓
Air line to platform			○
Automotive-style horn		○	○
AC power to platform	✓	✓	✓
Descent, tilt and motion alarm	✓	✓	✓
Diamond plate platform deck	✓	✓	✓
Dual LED flashing beacons	✓	✓	✓
Electric horn	✓	✓	✓
Lanyard attachment points	✓	✓	✓
Platform control guard (PCON)	✓	✓	✓
Platform load sense system	✓	✓	✓
Proportional drive and lift	✓	✓	✓
SmartLink dual zone control system	✓	✓	✓
Chassis			
Lift Connect Telematics		○	○
Lift Connect with Access Manager upgrade		○	○
Biodegradable hydraulic oil			○
Lift Guard White Noise Alarm		○	○
Lift Tools Spill Guard (E-Drive)			○
Auto leveling hydraulic outriggers (GS-3232)	✓	✓	✓
Auxiliary platform lowering	✓	✓	✓
Driveable at full height (GS-3246 only)	✓	✓	✓
Dual front wheel sealed AC electric drive motors (E-Drive)	✓	✓	✓
Electric brake release (E-Drive)	✓	✓	✓
On board diagnostic system with battery charge indicator	✓	✓	✓
Pothole protection	✓	✓	✓
Side and rear fork pockets	✓	✓	✓
Solid non-marking tires	✓	✓	✓
Tech Pro Link connector	✓	✓	✓
Tie-down and lifting points	✓	✓	✓

- S Standard
- S+ Standard +
- BtO Build to Order
- ✓ Standard Features
- Options



Indoor & Outdoor Use



Side Forklift Pockets



E-Drive



CHERRY PICKER•IE

