

Genie® GS™ -2632 & GS-2646



Specifications

ANSI A92.20, CSA B354.6

Models	GS-2632		GS-2646	
Measurements	US	Metric	US	Metric
Working height max. - indoor ⁽¹⁾	32 ft 1 in	9.96 m	32 ft 1 in	9.96 m
Working height max. - outdoor ⁽¹⁾	25 ft	7.79 m	25 ft 8 in	7.99 m
A Platform height max. - indoor	26 ft 1 in	7.96 m	26 ft 1 in	7.96 m
A Platform height max. - outdoor	19 ft	5.79 m	19 ft 8 in	5.99 m
B Platform height - stowed	3 ft 11 in	1.19 m	3 ft 11 in	1.19 m
C Platform length - outside	7 ft 5 in	2.26 m	7 ft 5 in	2.26 m
C Platform length - outside, extended	10 ft 5 in	3.18 m	10 ft 5 in	3.18 m
Slide-out platform extension deck - length	3 ft	0.91 m	3 ft	0.91 m
D Platform width - outside	32.9 in	0.84 m	3 ft 10 in	1.18 m
Guardrail height	3 ft 7 in	1.10 m	3 ft 7 in	1.10 m
Toeboard height	6 in	15 cm	6 in	15 cm
E Machine Height - stowed (folding rails)	7 ft 7 in	2.31 m	7 ft 7 in	2.31 m
Machine Height - stowed (rails lowered)	6 ft 4 in	1.94 m	5 ft 7 in	1.70 m
F Length machine - stowed	8 ft	2.44 m	8 ft	2.44 m
F Length machine - stowed, extended	10 ft 11 in	3.33 m	10 ft 11 in	3.33 m
G Width	32.2 in	0.82 m	3 ft 10 in	1.18 m
H Wheelbase	6 ft 1 in	1.85 m	6 ft 1 in	1.85 m
I Ground clearance (center) - pothole guards retracted	5 in	12 cm	5 in	12 cm
I Ground clearance - pothole guards deployed	0.9 in	2.30 cm	0.9 in	2.30 cm

Productivity

Max. platform occupancy (in/out)	2/1		2/1	
Lift capacity	500 lb	227 kg	1,000 lb	454 kg
Lift capacity - extension deck extended	250 lb	113 kg	250 lb	113 kg
Max. platform drive height	26 ft 1 in	7.96 m	26 ft 1 in	7.96 m
Drive speed - stowed	2.0 mph	3.2 km/h	2.0 mph	3.2 km/h
Drive speed - raised	0.5 mph	0.8 km/h	0.5 mph	0.8 km/h
Gradeability - stowed ⁽²⁾	25%		25%	
Turning radius - inside/outside	0/7 ft	0/2.13 m	0/7 ft 6 in	0/2.29 m
Lifting speed - raise/lower	43/33 sec		41/30 sec	
Tilt sensor activation (front to back/side to side)	3°/1.5°		3°/1.5°	
Tires - solid non-marking	15x5 in	38x13 cm	15x5 in	38x13 cm

Power

Power - FLA	24V DC (4x6V 210Ah)	24V DC (4x6V 210Ah)
Power - Lithium-Ion	24V DC (1x24V 90Ah)	24V DC (1x24V 90Ah)
Hydraulic tank capacity (E-Drive)	4 gal	15L

Weight(3) and Floor Loading⁽⁴⁾

Weight	4,729 lb	2,145 kg	4,346 lb	1,971 kg
Weight max. (adding all possible options)	4,900 lb	2,223 kg	4,542 lb	2,060 kg
Tire load max.	1,820 lb	826 kg	2,127 lb	965 kg
Tire contact pressure	119 psi	824 kPa	124.6 psi	935 kPa
Occupied floor pressure	270 psf	12.91 kPa	192 psf	9.83 kPa

Sound and Vibration Levels

Sound Pressure level (ground workstation)	< 70 dBA	< 70 dBA
Sound Pressure level (platform workstation)	< 70 dBA	< 70 dBA
Vibrations	< 8 ft 2 in/s ²	< 2.5 m/s ²

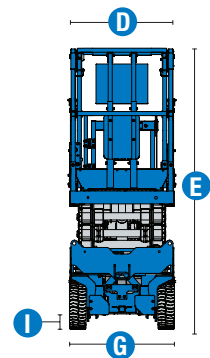
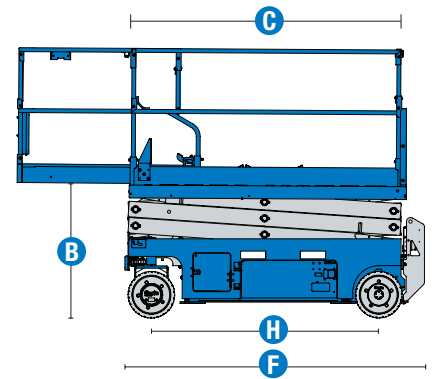
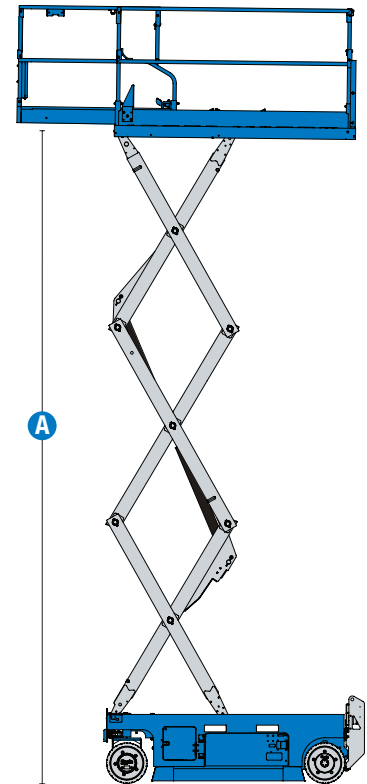

CHERRY PICKER·IE

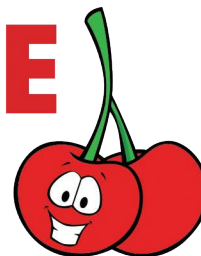

Genie® GS™ -2632 & GS-2646

SKU: Standard Model

- **GS2632E1AE0003:** GS-2632, E-Drive

SKU: Standard Model

- **GS264601AE0003:** GS-2646, E-Drive

* Build to Order

Option availability	S	S+	BtO
Power			
Standard FLA flooded lead acid batteries	✓	✓	✓
AGM Maintenance-free batteries		○	○
Lithium-Ion battery			○
Drive cut-out while charging		○	○
Power Inverter		○	○
Rear recessed charger receptacle	✓	✓	✓
Platform			
Folding rails, Full-height swing gate (GS-2646)	✓	✓	✓
Folding rails, Half-height swing gate (GS-2632)	✓	✓	✓
Slide out extension deck	✓	✓	✓
Air line to platform			○
Automotive-style horn		○	○
AC power to platform	✓	✓	✓
Descent, tilt and motion alarm	✓	✓	✓
Diamond plate platform deck	✓	✓	✓
Dual LED flashing beacons	✓	✓	✓
Electric horn	✓	✓	✓
Lanyard attachment points	✓	✓	✓
Platform control guard (PCON)	✓	✓	✓
Platform load sense system	✓	✓	✓
Proportional drive and lift	✓	✓	✓
SmartLink dual zone control system	✓	✓	✓
Chassis			
Lift Connect Telematics		○	○
Lift Connect with Access Manager upgrade		○	○
Biodegradable hydraulic oil			○
EE Certification (Hydraulic drive)			○
Lift Guard White Noise Alarm		○	○
Lift Tools Spill Guard (E-Drive)			○
Auxiliary platform lowering	✓	✓	✓
Driveable at full height	✓	✓	✓
Dual front wheel sealed AC electric drive motors (E-Drive)	✓	✓	✓
Electric brake release (E-Drive)	✓	✓	✓
On board diagnostic system with battery charge indicator	✓	✓	✓
Pothole protection	✓	✓	✓
Side and rear fork pockets	✓	✓	✓
Solid non-marking tires	✓	✓	✓
Tech Pro Link connector	✓	✓	✓
Tie-down and lifting points	✓	✓	✓

- S Standard
- S+ Standard +
- BtO Build to Order
- ✓ Standard Features
- Options



Indoor & Outdoor Use



Side Forklift Pockets



Optional E-Drive



CHERRY PICKER • IE



Sales & Service



Bespoke Design



MEWP Training



Handling Solutions

