

# Genie® GS™ -1932

## Specifications CE, UKCA

Models	GS-1932	
Measurements	US	Metric
Working height max. - indoor <sup>(1)</sup>	24 ft 6 in	7.64 m
Working height max. - outdoor <sup>(1)</sup>	20 ft	6.27 m
<b>A</b> Platform height max. - indoor	18 ft 6 in	5.64 m
<b>A</b> Platform height max. - outdoor	14 ft	4.27 m
<b>B</b> Platform height - stowed	2 ft 11 in	0.89 m
<b>C</b> Platform length - outside	6 ft 2 in	1.88 m
<b>C</b> Platform length - outside, extended	9 ft 2 in	2.79 m
Slide-out platform extension deck - length	3 ft	0.91 m
<b>D</b> Platform width - outside	2 ft 6.5 in	0.78 m
Guardrail height	3 ft 7 in	1.10 m
Toeboard height	6 in	15 cm
<b>E</b> Machine Height - stowed (fixed guardrails or folding rails up)	6 ft 7 in	2.00 m
Machine Height - stowed (rails lowered)	4 ft 11 in	1.50 m
<b>F</b> Length machine - stowed (integrated ladder or w/out ladder)	6 ft 2 in	1.88 m
Length machine - stowed, extended	9 ft 2 in	2.79 m
<b>G</b> Width	2 ft 8 in	0.81 m
<b>H</b> Wheelbase	5 ft 1 in	1.55 m
<b>I</b> Ground clearance (center) - pothole guards retracted	4 in	10 cm
<b>I</b> Ground clearance - pothole guards deployed	0.8 in	2 cm

### Productivity

Max. platform occupancy (in/out)	2/1	
Lift capacity	500 lb	227 kg
Lift capacity - extension deck extended	250 lb	113 kg
Max. platform drive height	18 ft 6 in	5.64 m
Drive speed - stowed	2.5 mph	4.0 km/h
Drive speed - raised	0.5 mph	0.8 km/h
Gradeability - stowed <sup>(2)</sup>	25%	
Turning radius - inside/outside	0/5 ft 11 in	0/1.80 m
Lifting speed - raise/lower	33/30 sec	
Tilt sensor activation (front to back/side to side)	3° / 1.5°	
Tires - solid non-marking	12x4.5 in	31x11 cm

### Power

Power - FLA <sup>(3)</sup>	24V DC (2x12V 150Ah)	
Power - AGM	24V DC (2x12V 145Ah)	
Power - Lithium-Ion	24V DC (1x24V 90Ah or 100Ah)	
Hydraulic tank capacity	1.6 gal	6.1 L

### Weight(4) and Floor Loading<sup>(5)</sup>

Weight	2,820 lb	1,279 kg
Weight max. (adding all possible options)	3,080 lb	1,397 kg
Tire load max.	1,415 lb	642 kg
Tire contact pressure	157.2 psi	1,084 kPa
Occupied floor pressure	218 psf	10.42 kPa

### Sound and Vibration Levels

Sound Pressure level (ground workstation)	< 70 dBA	
Sound Pressure level (platform workstation)	< 70 dBA	
Vibrations	< 8 ft 2 in/s <sup>2</sup>	< 2.5 m/s <sup>2</sup>

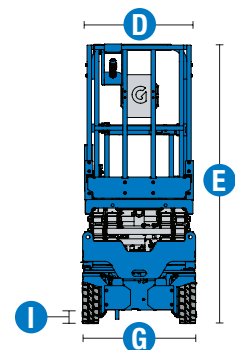
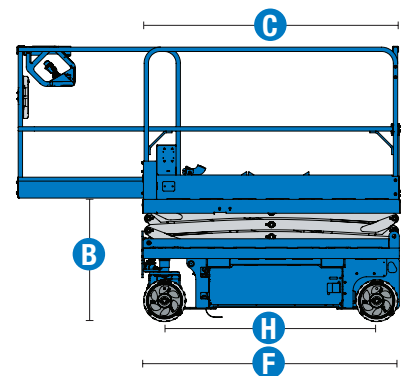
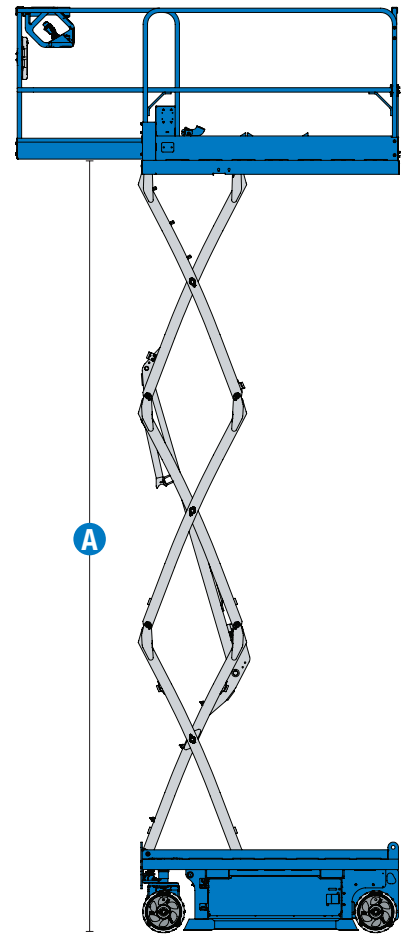

Electric Slab Scissor Lifts

## Genie® GS™ -1932

**SKU: Standard Model** CE, UKCA

- **GS1932E1CE0074:** GS-1932, E-Drive, 110V, PTP, Fixed rails
- **GS1932E1CE0075:** GS-1932, E-Drive, 220V, PTP Ready, Fixed rails
- GS-1932, E-Drive, E-Lift, Lithium-Ion\*

\* Build to Order

Option availability		S	S+	BtO
Power	AGM Maintenance-free batteries	✓	✓	✓
	Lithium-Ion battery, UL certified			○
	Power Inverter		○	○
	Rear recessed charger receptacle	✓	✓	✓
Platform	Fixed rails, Half-height swing gate	✓	✓	✓
	Folding rails, Half-height swing gate			○
	Slide out extension deck	✓	✓	✓
	Power to platform Pre-arrangement (PTP Ready)	✓	✓	✓
	Power to platform no RCBO		○	○
	Power to platform with RCBO		○	○
	Air line to platform		○	○
	Automotive-style horn		○	○
	Descent, tilt and motion alarm	✓	✓	✓
	Diamond plate platform deck	✓	✓	✓
	Dual LED flashing beacons	✓	✓	✓
	Electric horn	✓	✓	✓
	Lanyard attachment points	✓	✓	✓
	Platform control guard (PCON)	✓	✓	✓
	Platform load sense system	✓	✓	✓
Proportional drive and lift	✓	✓	✓	
SmartLink dual zone control system	✓	✓	✓	
Chassis	Telematics-ready		○	○
	Lift Connect Telematics		○	○
	Lift Connect with Access Manager upgrade		○	○
	Eco32 biodegradable hydraulic oil		○	○
	E-Lift, E-Steer			○
	Battery Guard - Anti-theft		○	○
	Lift Guard White Noise Alarm		○	○
	Lift Tools Spill Guard			○
	Software cut-out while charging (Drive or Drive & Lift)		○	○
	Auxiliary platform lowering	✓	✓	✓
	Driveable at full height	✓	✓	✓
	Dual front wheel sealed AC electric drive motors	✓	✓	✓
	Electric brake release	✓	✓	✓
	On board diagnostic system with battery charge indicator	✓	✓	✓
	Pothole protection	✓	✓	✓
Side and rear fork pockets	✓	✓	✓	
Solid non-marking tires	✓	✓	✓	
Tech Pro Link connector	✓	✓	✓	
Tie-down and lifting points	✓	✓	✓	

- S Standard
- S+ Standard +
- BtO Build to Order
- ✓ Standard Features
- Options



Durable Link Stack Design



More Platform Workspace



Standard Fixed Guard Rails

