

UpRight MX19 Battery Scissors Lift

Dimensions

A. Overall Length	5.7 ft in	1750 mm
B. Overall Width	2.5 ft in	760 mm
C. Height w/ Rails	7 ft in	2130 mm
E. Ground Clearance Platform	3.7 in	95 mm
F. Max Platform Height	19 ft in	5800 mm
G. Platform Width	28.3 in	720 mm
H. Platform Length	100 in	2540 mm
I. Deck Extension	in	mm

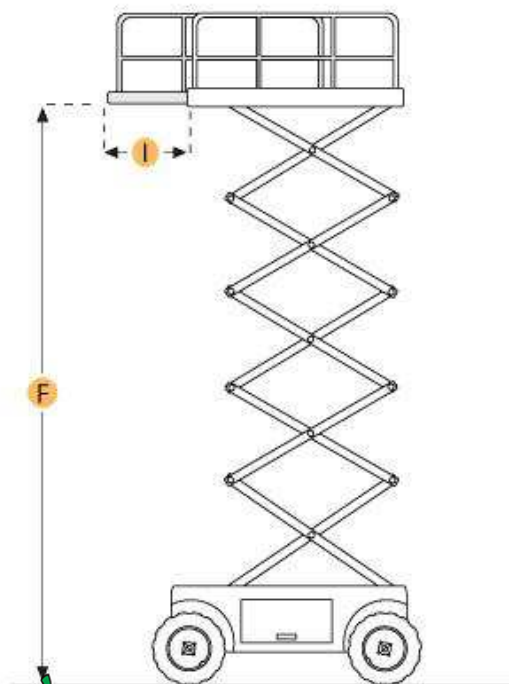
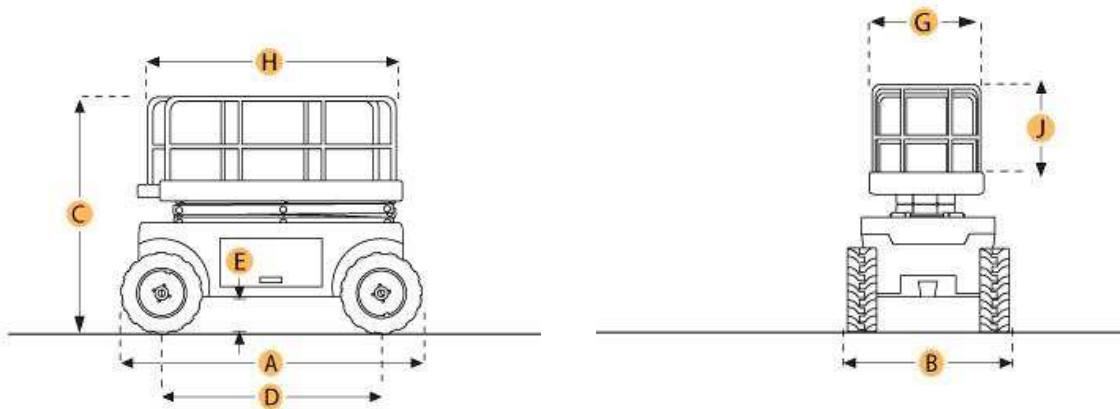

Distributed By



Specification

Engine		
Make		
Model		
System Voltage	24 V	
Number of Batteries	4	
Battery Amp Hours	220	
Charger Amps	25 amps	
Operational		
Operating Weight	3218.7 lb	1460 kg
Max Speed	2.3 mph	3.7 km/h
Tire Size	305mm dia	
Tire Fill/Type	solid / non-marking	
Platform		
Max Working Height	25.6 ft in	7800 mm
Max Platform Height	19 ft in	5800 mm
Max Platform Weight Capacity	500.4 lb	227 kg
Platform Length	100 in	2540 mm
Platform Width	28.3 in	720 mm
Lift Time	19 sec	
Lower Time	18 sec	
Deck Extension	in	mm
Dimensions		
Overall Length	5.7 ft in	1750 mm
Overall Width	2.5 ft in	760 mm
Height w/ Rails	7 ft in	2130 mm
Height w/o Rails	5.2 ft in	1600 mm
Ground Clearance	3.7 in	95 mm

Distributed By

