

KILMOON BUSINESS PARK, ASHBOURNE, CO. MEATH, A84 F776
TEL: 01 835 4788 sales@cherrypicker.ie www.cherrypicker.ie

Stock Picker 51MP specifications



Quick and nifty,
it is ideal for moving
about in tight spaces
and in shop aisles



QUICK AND EASY TO USE
It is extremely easy to handle with quick
selfpropulsion: 5 km/h at top speed.
It has a zero turning circle.

SELF PROPELLED WHEN RAISED - MAXIMUM WORKING HEIGHT OF 5,10 M



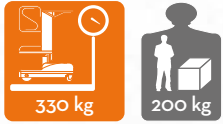

FULLY ALUMINUM



MAXIMUM PRODUCTIVITY IN A SMALL SPACE.

Thanks to its compact size (77 x 143 cm) and a large and sturdy electric picking platform (with a stroke of 640 mm) the productivity of your company will increase.

COMPLETE CONTROL
 IN ONE HAND THANKS
 TO THE SINGLE LEVER JOYSTICK



CUSTOMIZABLE PICKING PLATFORM
 Several possibilities to customize the picking platform based on customers' needs.
 (Details on p. 49)



EXTENSIBLE



FOLDING EDGES.



**EXTRALONG
 FIXED PICKING
 PLATFORM**



SOME ACCESSORIES AND CUSTOMISATION



4KIT: kit with 4 Batteries to double machine's autonomy.



RL: side rollers to drive through shelf aisles.

➤ **OTHER ACCESSORIES AND CUSTOMISATION ON P. 46**



Technical data

Max. working height	5,10 m	
Max capacity	200 kg	
Number of people	1	
Use	Internal - External	
A	Closed machine height	1430 mm
B	Minimum platform height	325 mm
C	Maximum platform height	3000 mm
D/E	Base overall dimensions	770 x 1410 mm
F/G	Cage dimensions	580 x 740 mm
Machine weight	330 kg	
Drive wheels dimension	Ø 300 x 76	
Swivel wheels dimensions	Ø 150 x 40	



PICKING PLATFORM

Adjustment	electrical	
H	Stroke	640 mm
Min. height from the ground	690 mm	
Max. height from the ground	4010 mm	
I/J	Dimensions	780 x 760 mm
Capacity	100 kg	

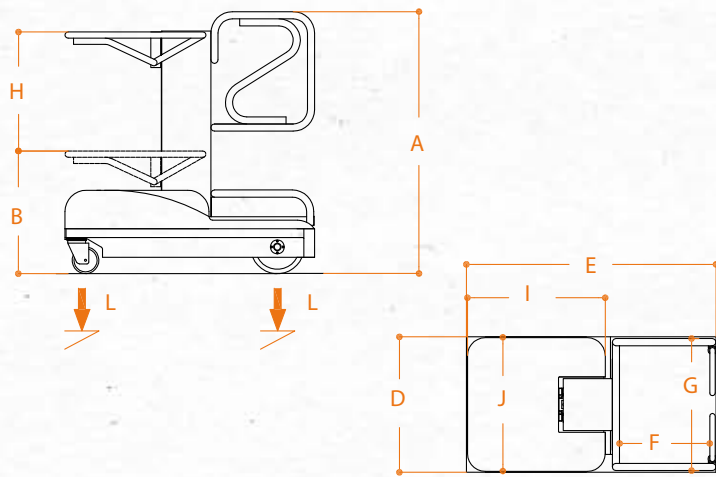

PERFORMANCE

Power supply	electrical	
Batteries	2 AGM 12V 85 Ah	
Battery charger	110V - 220V	
K	Maximum climbing ability	15%
Climbing ability at height	5%	
Internal turning radius	0	
External turning radius	1380 mm	
Max. speed (rising – descending)	0,15 m/s	
Maximum shifting speed (on the ground - at height)	1,25 - 0,42 m/s	
L	Maximum pressure for wheel at full load*	1,90 kN
Work cycles ** (with fresh batteries)	Ca. 100	

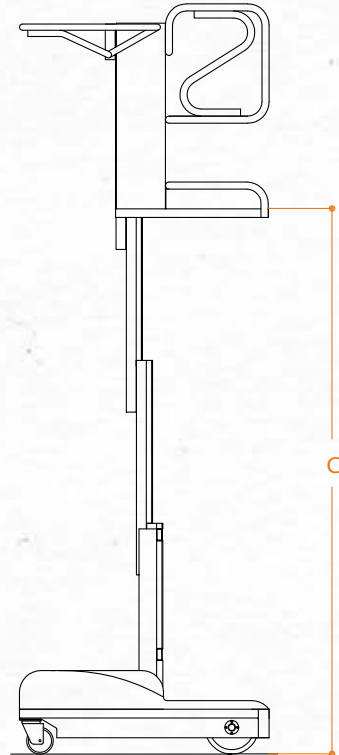

* Maximum pressure whereas the weight of the platform plus the maximum load on the basket are completely distributed on one side of the platform (totally asymmetric load).

** By work cycle we mean a self-propelled movement of 20 m with a full ascent to and descent from the maximum height and with adjustment of the loading platform.