

VERTICAL MAST LIFT M1230E

DIMENSIONS	M1230E
Max. working height	17 ft 11 in
Max. platform height (A)	11 ft 11 in
Platform size	29 in x 38 in
Overall length (D)	53 in
Overall width (B)	30 in
Stowed height (C)	64 in
Ground clearance	3 in

PERFORMANCE	
Platform capacity (SWL)	500 lbs
Max. drive height	11 ft 11 in
Max. drive speed (stowed)	2 mph
Max. drive speed (elevated)	0.4 mph
Raise/lower time	18/25 sec
Gradeability	25%
Max. operating slope (side to side)	1.5°
Max. operating slope (front to back)	2°
Inside turning radius	14.4 in
Outside turning radius	58.5 in
Tires	12 in dia. solid rubber, non-marking
Parking brake	2 wheel, spring-applied, hydraulically-released with manual overdrive
Drive system	dual front hydraulic motors
Controls	proportional

POWER	
Power source	24V 4hp DC electric motor 4-220 Ah batteries
Battery charger	90V-240V - 18 amp automatic

WEIGHT	
Weight	1,720 lbs

TURNING RADIUS

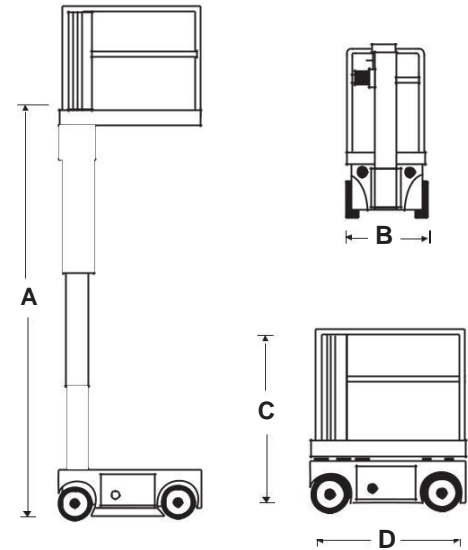
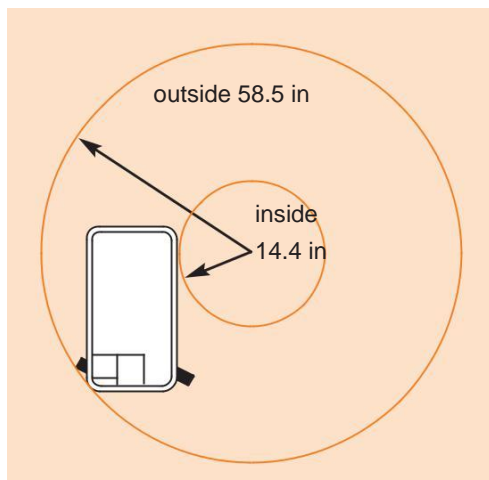

STANDARD FEATURES

- Proportional controls
- Descent and tilt alarms
- High amp hour rating gives long usage between charges
- Emergency lowering at chassis controls
- Non-marking, solid rubber tires
- Power line to platform
- Forklift pockets
- Saloon door-style platform entry
- Horn
- Tie down points
- 2 persons + equipment capacity indoors
- 1 person + equipment capacity outdoors
- Selectable motion alarm
- ANSI compliant

OPTIONS

- Special paint colors
- 20 in roll-out extension deck
- Environmental green oil
- CSA compliant