



LOW PROFILE STATIC SCISSOR TABLE

- 1000kg capacity
- Standard or U shaped design (Euro Pallet) for loading with a pallet truck



TECHNICAL FEATURES

- 3 Phase mains powered tables, 13amp isolator
- These tables achieve a low closed height, eliminating the need for pit installation
- All tables are manufactured to European standard – EN1570:2011
- Remote power pack mounted on pedestal, protected to IP 54
- Suitable for light, infrequent use
- Upper platform fitted with safety trip bar to prevent decent on detection of obstruction
- Check valve included for slow, controlled lowering in the event of a burst hose. The safety trip bar will still prevent the table from dropping altogether if it is still powered.
- Removable lifting eyes to facilitate handling installation and inspection



TECHNICAL SPECIFICATION

“U” Shape low profile table (585mm gap for pallet truck access)

	CAPACITY	A RAISED HEIGHT	B CLOSED HEIGHT	C PLATFORM WIDTH	D PLATFORM LENGTH	LIFTING TIME	POWER PACK	NET WEIGHT
BD-HU-1000	1000KG	875mm	90mm	1140mm	1450mm	21 sec	AC 0.75	280KG

Standard low profile table (these tables are supplied with loading ramps 905mm long, 1140mm wide - against the short side)

	CAPACITY	A RAISED HEIGHT	B CLOSED HEIGHT	C PLATFORM WIDTH	D PLATFORM LENGTH	LIFTING TIME	POWER PACK	NET WEIGHT
BD-HY-1001	1000KG	875mm	90mm	1140mm	1450mm	21 sec	AC 0.75	280KG

Both models are held in stock

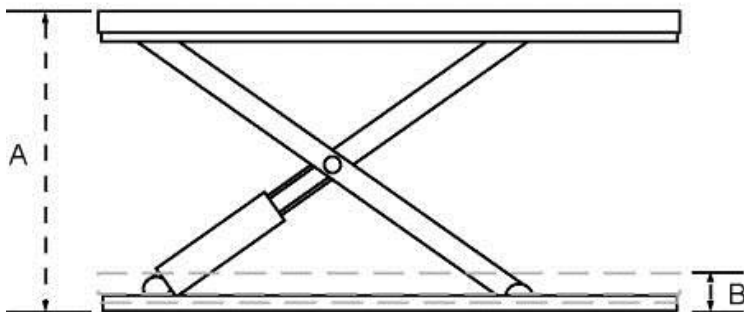

side elevation

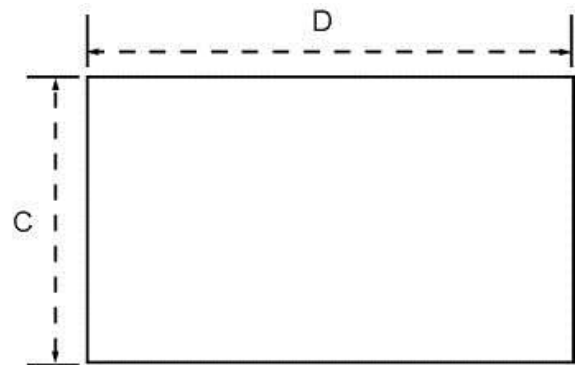

platform specification

