



Level & Turn CP1500

Level & Turn CP1500s are true ergonomic tools in every sense of the word.

They are designed to eliminate worker bending by automatically raising and lowering pallets during loading or unloading without the use of mechanical springs. Level & Turn CP1500s also allow easy pallet rotation so the user does not have to reach or strain. As the load weight changes, the Level & Turn CP1500 automatically adjusts, keeping the top of the load at a convenient working height. The patented pneumatic operating system found only in the Level & Turn CP1500 has proven to be the top choice of industry professionals worldwide.



TECHNICAL FEATURES

- Self-levelling design automatically keeps the top of the load at a convenient working height to help eliminate bending and improve productivity.
- Integral rotator ring helps eliminate reaching and stretching.
- Captive air operation eliminates cumbersome mechanical springs and gives more controlled (dampened) movement to the platform.
- Infinitely adjustable for varied loads by simply adding or bleeding air – no difficult changing of springs required.
- Pressure gauge and air valves are protected, yet located for easy access.
- Secured ball-bearing centre pivot of the rotator ring provides smooth, even rotation.
- Pressure relief valve prevents excess pressure build-up.
- Heavy-duty structural steel construction to handle tough industrial environments
- Surfaces are phosphated and powder coated for a lasting, durable finish.
- Safety finger guards under the rotator ring are fitted as standard
- Easily transportable within the workplace by fork lift truck
- CE marked



TECHNICAL SPECIFICATION

| Model | Minimum Self Levelling Capacity | Maximum Self Levelling Capacity | Maximum Capacity | Raised Height (C) | Closed Height (B) | Rotator Ring Dia (A) | Base Length (D) | Base Width (E) | Ship Weight |
|--------|---------------------------------|---------------------------------|------------------|-------------------|-------------------|----------------------|-----------------|----------------|-------------|
| CP1500 | 113 kg | 1588 kg | 1814 kg | 775 mm | 267 mm | 1092 mm | 1245 mm | 617 mm | 240 kg |

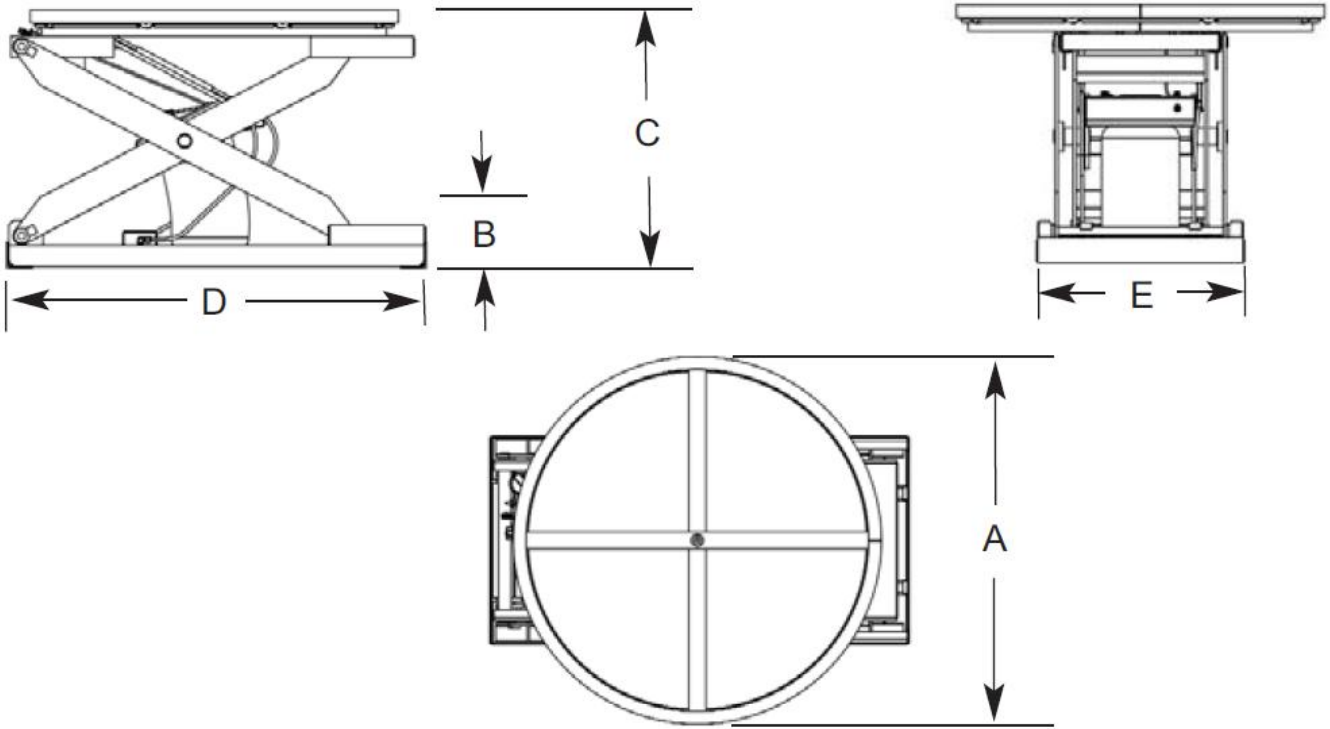

Air Pressure Capacity Adjustment = Infinite (10 – 60 psi / 0.7 – 4.1 bar)
 On-board Capacity Adjustment = 3 position knob (light – medium – heavy)

Special Options:

- PVC Bellows
- Square platform (fixed or rotating)
- Mobile base frame
- Fork pockets
- Squaring stops
- Stainless steel / galvanised finish