



## Reel Rotator – handling of heavy reels

When transporting, lifting and rotating heavy reels, the Reel Rotator is the perfect choice! It is compact, very manoeuvrable and ensures the user ergonomically correct working conditions.

The reels are fixed with gripping arms, having rubber-covered gripping pads to achieve the largest friction and to ensure a gentle grip. The Reel Rotator manages soft as well as smooth and hard reels.

High focus on safety! None of the models can open the gripping arms by mistake, and the reels can only be released, when placed on floor or pallet. On models with electric rotation, it is only possible to rotate at lifting heights above 825 mm, so that the gripping arms cannot touch floor or legs.

The Reel Rotator is available in four unique models, with manual or electric rotation, reel fastening/ releasing and lifting.





## Technical Specifications

Available in four models and can handle

- Vertical reels placed on floor or pallet
- Horizontal and vertical reels that are clear off the floor

On trucks with manual rotation, the tilt degree can be set for every 90° (with a locking system). Trucks with electric rotation have programmable tilt degree.



Opening the gripping arms by mistake is not possible. Clear indication whether the clamping force is sufficient for lifting/rotating.



All models are available with straddle legs.



The electric trucks have remote control for reel fastening/releasing.

Product (measured in mm)	LFRRM 1001	ELFRM 1001	ELFRRE 1001	SELFRE MAXI 1002
Capacity in kg	500	500	500	500
Reel diameter	120 - 1250 (two-points clamping: 120 - 1250, three-points clamping: 800 - 1250)			
Opening gripping arms	max. 1300			
Lifting height	h <sub>3</sub> 1750			
Overall height	h <sub>1</sub> 1925			1930
Overall width	b <sub>1</sub> 1130			
Overall width gripping arms	b <sub>1-1</sub> 1430			
Width between legs	b <sub>4</sub> 285			
Overall length	l <sub>1</sub> 1620	1730	1730	1795
Lowered height	h <sub>13</sub> 225			
Rotation height	min. 825			
Gangway	A <sub>st</sub> 2290 - tests show that 1700 mm are enough			2200 - tests show that 1700 mm are enough
Turning angle of the wheels	210°			
Driving motor				1,2 kW 24 V speed control electronically variable
Driving speed with/without load				Below 500mm lift: 5/6 km/h, over 500 mm lift: 3/4 km/h
Pump motor	1,1 kW 12 V		1,1 kW 12 V	1,2 kW 24 V
Lifting speed with/without load	Normal / quick: 8/26 mm per pump	0,05 / 0,07 m/s	0,05 / 0,07 m/s	0,07 / 0,12 m/s
Lowering speed with/without load	Max. 0,19 m/s / Max. 0,07 m/s	0,12 / 0,04 m/s	0,12 / 0,04 m/s	0,12 / 0,07 m/s
Weight in kg (no battery)	380	410	410	480

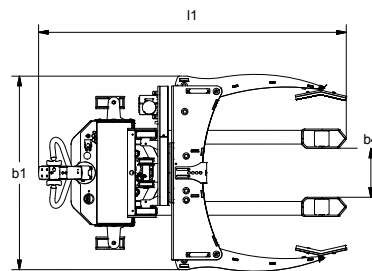
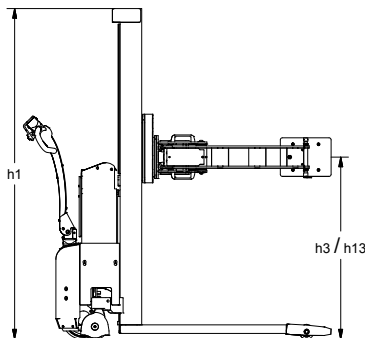

Can be adjusted for two-points or three-points clamping:

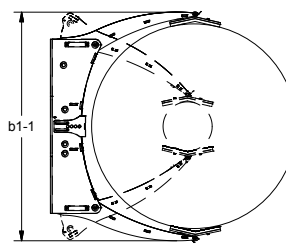

Two-points clamping

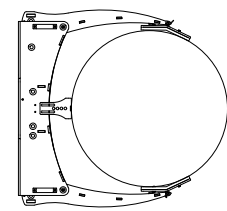

Three-points clamping

We also offer tailor-made solutions.

Please ask for further information or visit our website [www.cherrypicker.ie](http://www.cherrypicker.ie)