

Genie GS1932

Electric Scissor Lift

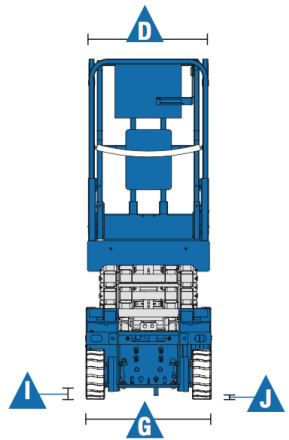

A) Working height maximum	7.79m – 25ft
B) Platform height maximum w/load sense	5.79m – 19ft
C) Platform height – stowed	1.00m – 3ft 4in
Platform length – outside	1.63m – 5ft 4in
Platform length – extended	2.43m – 8ft 4in
D) Slide-out platform extension deck	0.91m – 3ft
Platform width – outside	0.74m – 2ft 5in
Guardrail height	1.10m – 3ft 7in
E) Toeboard height	0.15m – 6in
F) Height – stowed: folding guardrails	2.11m – 6ft 11in
Rails folded	1.75m – 5ft 9in
G) Length - stowed	1.83m – 6ft
Length – stowed extended	2.74m – 9ft
H) Width	0.813m – 2ft 8in
I) Wheelbase	1.32m – 4ft 4in
J) Ground clearance – center with pothole guards deployed	6cm – 2.4in 2cm – 0.75in

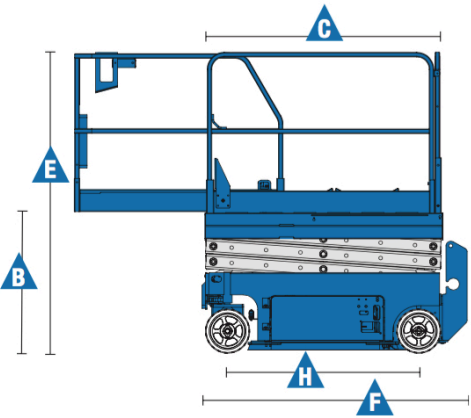
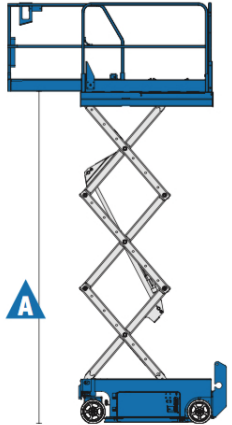

Features

STANDARD FEATURES

MEASUREMENTS

- GS™-1532**
- 6.57 m (21 ft) working height
 - Up to 272 kg (600 lb) lift capacity
- GS™-1932**
- 7.79 m (25 ft) working height
 - Up to 227 kg (500 lb) lift capacity

PRODUCTIVITY

- 1.63 m x 0.74 m (5 ft 4 in x 2 ft 5 in) steel platform
- Folding rails with half-height swing gate
- 0.91 m (3 ft) extension deck
- Dual front wheel drive
- Proportional lift and drive
- 30% gradeability
- Platform control with battery charge indicator and diagnostic display
- Manual platform lowering valve
- Emergency stop at both platform and ground controls
- Rear wheel multiple disc brakes
- Front wheel hydraulic dynamic braking
- Manual brake release
- Solid non-marking tyres
- Pothole guards
- Tilt alarm
- Descent alarm
- Electronic horn
- Hour meter
- Dual flashing beacons
- Motion alarm