

Genie® GR-12, GR-15 & GR-20

Specifications

Models	GR-12		GR-15		GR-20	
	US	METRIC	US	METRIC	US	METRIC
Working height max. - indoor ⁽¹⁾	17 ft 4 in	5.45 m	20 ft 8 in	6.47 m	25 ft 9 in	8.02 m
Working height max. - outdoor ⁽¹⁾	15 ft 1 in	4.80 m	17 ft 1 in	5.40 m	21 ft 6 in	6.70 m
Platform height max.- indoor	11 ft 4 in	3.45 m	14 ft 8 in	4.47 m	19 ft 9 in	6.02 m
Platform height max. - outdoor	9 ft 1 in	2.80 m	11 ft 1 in	3.40 m	15 ft 6 in	4.70 m
A B Platform dimensions (lengthxwidth) - Standard retracted	35x29.5 in	0.89x0.75 m	35x29.5 in	0.89x0.75 m	35x29.5 in	0.89x0.75 m
Platform dimensions (lengthxwidth) - Standard extended	55x29.5 in	1.4x0.75 m	55x29.5 in	1.4x0.75 m	55x29.5 in	1.4x0.75 m
C Height - stowed	5 ft 10 in	1.78 m	5 ft 10 in	1.78 m	6 ft 6 in	1.98 m
D Length- stowed	4 ft 5 in	1.35 m	4 ft 5 in	1.35 m	4 ft 5 in	1.35 m
E Width	2 ft 5.5 in	0.75 m	2 ft 5.5 in	0.75 m	2 ft 7.5 in	0.80 m
F Ground clearance (center)	2.5 in	6 cm	2.5 in	6 cm	2.5 in	6 cm

ANSI A92.20, CSA B354.6

Productivity

Maximum platform occupancy (in/out)	1/1		1/1		1/1	
Lift capacity	500 lb	227 kg	500 lb	227 kg	350 lb	159 kg
Lift capacity - extension deck extended	250 lb	113 kg	250 lb	113 kg	250 lb	113 kg
Drive speed - stowed	2.5 mph	4.0 km/h	2.5 mph	4.0 km/h	2.5 mph	4.0 km/h
Drive speed - raised	0.5 mph	0.8 km/h	0.5 mph	0.8 km/h	0.5 mph	0.8 km/h
Gradeability ⁽²⁾	30%		30%		30%	
Turning radius - inside	0 in	0 cm	0 in	0 cm	0 in	0 cm
Turning radius - outside	4 ft 4 in	1.32 m	4 ft 4 in	1.32 m	4 ft 4 in	1.32 m
Lifting speed - raise/lower	20/18 sec		21/19 sec		24/21 sec	
Controls - proportional	24V DC		24V DC		24V DC	
Tires - Solid non-marking	10x3x8 in	25x8x20 cm	10x3x8 in	25x8x20 cm	10x3x8 in	25x8x20 cm
Tilt sensor activation (front to back/side to side)	3° / 1.5°		3° / 1.5°		3° / 1.5°	

Power

Power	24V (4x6V 225Ah)		24V (4x6V 225Ah)		24V (4x6V 225Ah)	
Hydraulic tank capacity	2.2 gal	8.33L	2.2 gal	8.33L	2.2 gal	8.33L

Weight⁽³⁾ and Floor Loading⁽⁴⁾

Weight	1,681 lb	763 kg	2,178 lb	988 kg	2,513 lb	1,140 kg
Tire load max.	680 lb	308 kg	720 lb	327 kg	870 lb	395 kg
Tire contact pressure	104.6 psi	721.3 KPa	110.8 psi	763.7 Kpa	133.8 psi	922.8 Kpa
Occupied floor pressure	200.87 psf	9.6 kPa	251.99 psf	12.1 kPa	250.39 psf	12.0 kPa

Sound and Vibration Levels

Sound Pressure level (ground workstation)	< 70 dBA		< 70 dBA		< 70 dBA	
Sound Pressure level (platform workstation)	< 70 dBA		< 70 dBA		< 70 dBA	
Vibrations	< 8 ft 2 in/s ²	< 2.5 m/s ²	< 8 ft 2 in/s ²	< 2.5 m/s ²	< 8 ft 2 in/s ²	< 2.5 m/s ²

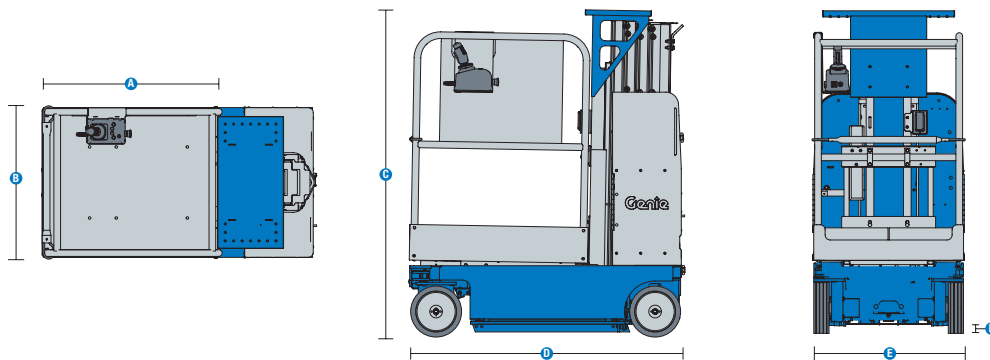

(1) The metric equivalent of working height adds 2m to platform height. U.S. adds 6ft to platform height.
 (2) Gradeability applies to driving on slopes and may vary depending on options and machine configurations. See operator's manual for details regarding slope ratings.
 (3) Weight refers to standard configuration and may vary depending on options and/or country standards.
 (4) Floor loading information is approximate and may vary depending on options and machine configurations. It should be used only with adequate safety factors.

Genie® GR-12, GR-15 & GR-20

SKU: Standard Model

- **GR120001AE0001:** GR-12, Gated extension platform
- **GR150001AE0002:** GR-15, Gated extension platform
- **GR200001AE0001:** GR-20, Gated extension platform

* Build to Order

Option availability		S	S+	BtO
Power	Standard FLA flood lead acid batteries	✓	✓	✓
	AGM maintenance-free batteries		○	○
	Power inverter		○	○
	Retractable Charging cord		○	○
Platform	Sliding mid-rail standard aluminum platform			○
	Sliding mid-rail extension aluminum platform			○
	Gated extension aluminum platform	✓	✓	✓
	Automotive-style horn		○	○
	Lift Tools Work Tray		○	○
	AC power to platform	✓	✓	✓
	Auxiliary platform lowering	✓	✓	✓
	Platform control guard	✓	✓	✓
	Platform load sense system	✓	✓	✓
	Proportional lift and drive	✓	✓	✓
	SmartLink dual zone control system	✓	✓	✓
Chassis	Lift Connect Telematics		○	○
	Lift Connect with Access Manager upgrade		○	○
	Biodegradable hydraulic oil			○
	Drive cut-out while charging		○	○
	Lift Guard White Noise Alarm		○	○
	Descent, tilt, and motion alarm	✓	✓	✓
	Dual LED flashing beacons	✓	✓	✓
	Dual wheel multi-disc brakes	✓	✓	✓
	Hinged rear ABS covers for easy access	✓	✓	✓
	Hour meter	✓	✓	✓
	Hydraulic brake release	✓	✓	✓
	Large forklift pockets access	✓	✓	✓
	On-board diagnostic system with battery charge indicator	✓	✓	✓
	Overhead crane attachment point	✓	✓	✓
	Pothole protection	✓	✓	✓
	Solid non-marking tires	✓	✓	✓
	Tech Pro Link connector	✓	✓	✓
Tie-down attachment points	✓	✓	✓	

- S Standard
 - S+ Standard +
 - BtO Build to Order
 - ✓ Standard Features
 - Options
- ANSI A92.20, CSA B354.6



Zero Inside Turning Radius



Narrow Access



Low Entry Height

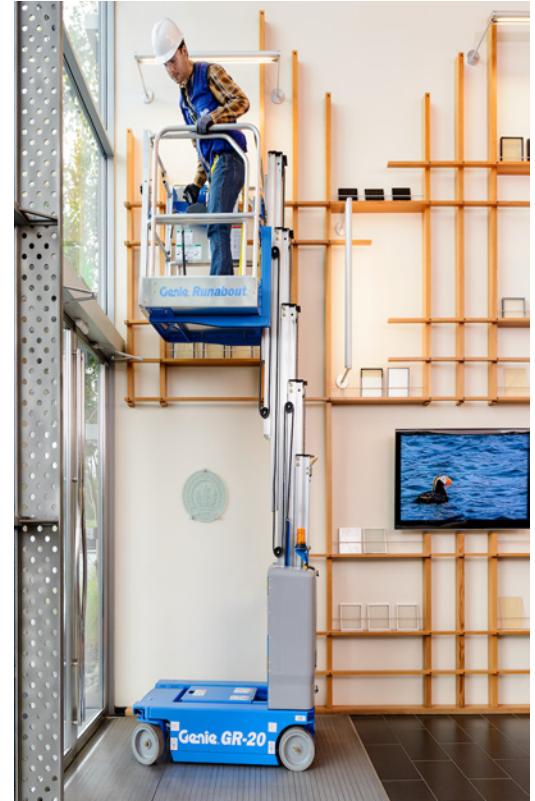

Product specifications are subject to change without notice or obligation. Photographs and/or drawings herein are for illustrative purposes only. Refer to the appropriate Operator's Manual for instructions on proper equipment use. Failure to follow instructions in the Operator's Manual may result in serious injury or death. The only warranty applicable to our equipment is the standard written warranty applicable to the particular product and sale and we make no other warranty, express or implied. Products and services listed may be trademarks, service marks or trade names of Terex Corporation and/or their subsidiaries in the USA and many other countries. Terex, Genie, Quality By Design, Xtra Capacity, Lift Power, Lift Guard, Lift Tools, Lift Connect and Tech Pro Link are registered trademarks of Terex Corporation or its subsidiaries.