

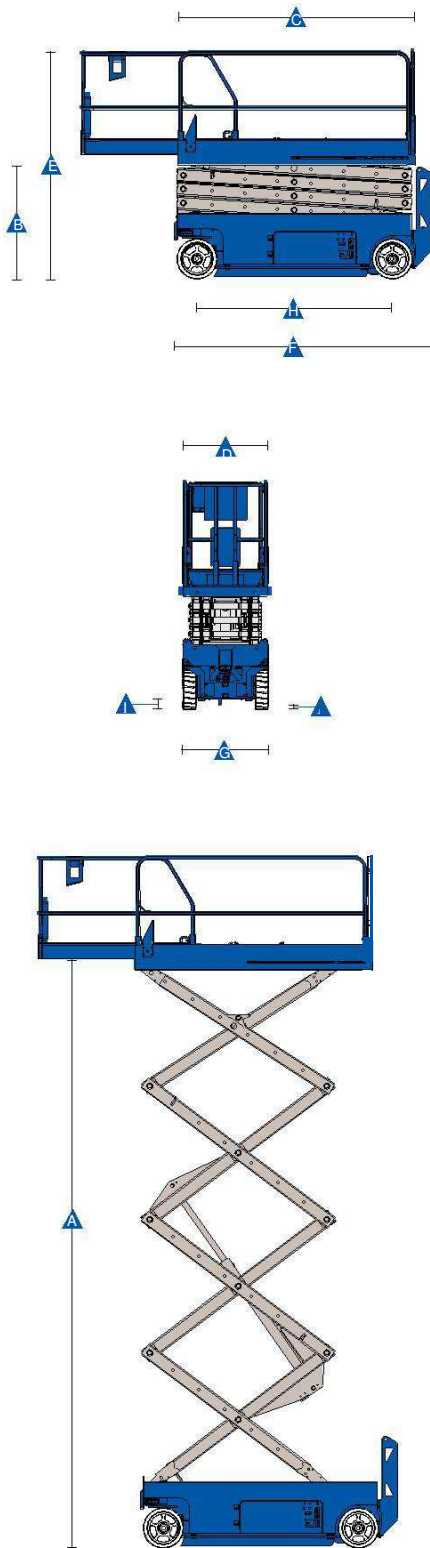

# Self-Propelled Scissor Lifts

GS™-4047



## Specifications

Model	GS-4047	
Measurements	US	Metric
Working height maximum*	45 ft	13.89 m
<b>A</b> Platform height maximum	39 ft	11.89 m
<b>B</b> Platform height - stowed	4 ft 5 in	1.34 m
<b>A</b> Platform length - outside	7 ft 5 in	2.26 m
- extended	10 ft 5 in	3.18 m
<b>A</b> Platform width - outside	3 ft 9.3 in	1.15 m
<b>E</b> Height - stowed: folding guardrails	8 ft 4 in	2.54 m
- rails lowered	6 ft 2	1.88 m
<b>F</b> Length - stowed	8 ft	2.44 m
- extended	11 ft	3.36 m
<b>G</b> Width	3 ft 11 in	1.19 m
<b>H</b> Wheelbase	6 ft 1 in	1.85 m
<b>A</b> Ground clearance - center	4 in	0.10 m
<b>A</b> - with pothole guards deployed	0.75 in	1.9 cm
Slide-out platform extension deck	3 ft	0.91 m
Guardrail height	3 ft 7 in	1.10 m
Toeboard height	6 in	0.15 m

## Productivity

Max platform occupancy	2	2
Lift capacity	550 lbs	249 kg
Drive height	Full height	
Drive speed - stowed	1.9 mph	3.1 km/h
Drive speed - raised	0.5 mph	0.8 km/h
Gradeability - stowed**	25%	25%
Turning radius - inside	zero	zero
Turning radius - outside	91 in	2.3 m
Raise/lower speed 71/41 sec	71/41 sec	
Controls	proportional	proportional
Drive	dual front wheel	dual front wheel
Multiple disc brakes	dual rear wheel	dual rear wheel
Tires solid non-marking	15 x 5 x 11 in	38 x 13 x 28 cm

## Power

Power source	24 V DC, 300 Ah (four 12 V, 150 Ah batteries in parallel series)	
Hydraulic system capacity	7.91 gal	36 L

## Weight\*\*\*

Base machine	7,185 lbs	3,260 kg
--------------	-----------	----------

**Standards Compliance** ANSI A92.6, CSA B354.2, CE Compliance, AS 1418.10

\* The metric equivalent of working height adds 2 m to platform height. U.S. adds 6 ft to platform height.

\*\* Gradeability applies to driving on slopes. Gradeability may vary depending on the weight of options installed on machine. See operator's manual for details regarding slope ratings.

\*\*\* Weight will vary depending on options and/or country standards.



# Self-Propelled Scissor Lifts

## GS™-4047

### Features

#### Standard Features

##### Measurements

GS-4047

- 45 ft (13.89 m) working height
- Up to 550 lbs (249 kg) lift capacity

##### Productivity

- Drive at full height
- Folding guardrails with full height swing gate
- Smart Link™ - proportional lift and drive
- Platform control with battery charge indicator
- AC power to platform
- Lanyard attachment points
- Manual platform lowering valve
- Emergency stop at both platform and ground controls
- Rear wheel multiple disc brakes
- Front wheel hydraulic dynamic braking
- Manual brake release
- Swing-out component trays
- Pothole guards
- Tilt level sensor with audible alarm
- Descent alarm
- Electronic horn
- Hour meter
- AC power to platform

##### Power

- 24 V DC battery pack
- 24 V DC, 300 Ah (four 12 V 150 Ah batteries in parallel series)
- Universal 20 amp smart charger

##### Platform

- 7 ft 5 in x 3 ft 9.3 in (2.26 x 1.15 m) steel platform
- 3 ft 9.3 in (0.91 m) extension deck

##### Drive

- Dual front wheel drive

##### Tires

- Solid non-marking

#### Options & Accessories

##### Productivity Options

- Air line to platform
- Dual flashing beacons
- Motion alarm
- Automotive-style horn

##### Power Options

- Power inverter (120 V/60 Hz)



Distributed By

**CHERRY PICKER**   
Ireland's Leading Supplier of Access Platforms



cherrypicker.ie



sales@cherrypicker.ie



353 (1) 835 4788



353 87 255 7755