



DRUM TURNER

Drum turner - optimum drum handling

High flexibility and efficiency - the drum turner handles drums in the horizontal or vertical position, and of different materials and dimensions.

The drum turner with the quick shift system can readily be fitted on all Logiflex models with adjustable carriage.

A wide range of optional extras ensures an optimum utilisation of the Logiflex - the same Logiflex can be fitted with e.g. spear, platform, crane arm and forks.

High quality is ensured through an extended test programme and in cooperation with experts in Health and Safety.





Technical Specifications

The drum turner can handle standard steel and plastic drums.

The drum turner has a capacity of 250 kg. The turning angle of 360° makes it possible to empty a drum.

The drum turner is available in a manual or electric rotation model. The electric drum turner has an electronic controller, ensuring

- speed and acceleration control
- delicate operation
- protection of gearbox
- long operating life

The gearing of the manual gear is 1:80.

The distance from the floor to the drum turner is 260 mm in lowered position.



Offers a wide range of optional extras, e.g. spear, platform, reel rotator and crane arm.



Manual drum turner is available for all models. Electric drum turner is only available for the electric models.



Quick shift makes it easy to replace the drum turner by other optional extras or forks.



The turning function of the electric model is operated by a remote control.



Using the unit without straddle legs, the drum has to be placed on a pallet or other suitable stand above floor level.

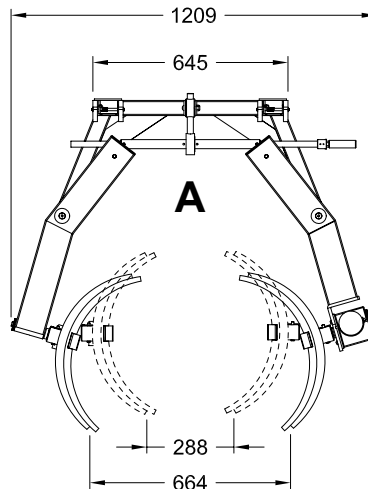

A: Drum turner for standard steel drums (DS/EN 210).

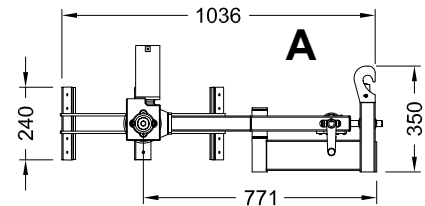

B: Drum turner for standard plastic drums (DS/EN 12707).

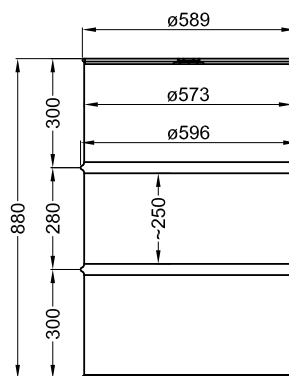
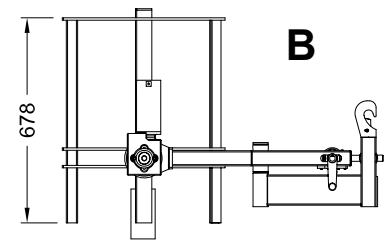

Standard steel drum (DS/EN 210).

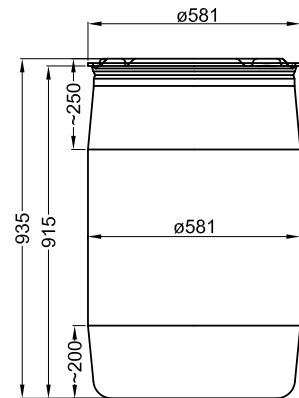

Standard plastic drum (DS/EN 12707).