



Aerial Work Platforms

AWP™ Super Series™

Specifications

Models	AWP-20S		AWP-25S		AWP-30S	
Measurements	Metric	US	Metric	US	Metric	US
Working height*	8.12 m	26 ft 1 in	9.57 m	30 ft 10 in	11.00 m	35 ft 6 in
Platform height	6.12 m	20 ft 1 in	7.57 m	24 ft 10 in	9.00 m	29 ft 6 in
A Height - stowed (Standard)	1.98 m	6 ft 6 in	1.98 m	6 ft 6 in	1.98 m	6 ft 6 in
stowed (RT/Narrow)	2.01 m	6 ft 7 in	2.01 m	6 ft 7 in	2.01 m	6 ft 7 in
B tilted back** (Standard)	_____	_____	_____	_____	_____	_____
C Length - stowed (Standard)	1.24 m	4 ft 1 in	1.31 m	4 ft 3.5 in	1.35 m	4 ft 5 in
stowed (RT/Narrow)	1.60 m	5 ft 3 in	1.60 m	5 ft 3 in	1.60 m	5 ft 3 in
D Length - tilted back**	_____	_____	_____	_____	_____	_____
E Width (Standard)	74 cm	2 ft 5 in	74 cm	2 ft 5 in	74 cm	2 ft 5 in
Width (RT)	76 cm	2 ft 6 in	76 cm	2 ft 6 in	76 cm	2 ft 6 in
Width (Narrow)	56 cm	1 ft 10 in	56 cm	1 ft 10 in	56 cm	1 ft 10 in

Productivity

Lift capacity	159 kg	350 lbs	159 kg	350 lbs	159 kg	350 lbs
Indoor:						
F G Outrigger footprint (l/w) (Standard)	1.55/1.35 m	5 ft 1 in/4 ft 5 in	1.75/1.55 m	5 ft 9 in/5 ft 1 in	1.93/1.73 m	6 ft 4 in/5 ft 8 in
Outrigger footprint (l/w) (RT/Narrow)	1.80/1.47 m	5 ft 11 in/4 ft 10 in	1.80/1.47 m	5 ft 11 in/4 ft 10 in	2.11/1.88 m	6 ft 11 in/6 ft 2 in
H Corner access*** (Standard)	38 cm	1 ft 3 in	48 cm	1 ft 7 in	56 cm	1 ft 10 in
Corner access*** (RT/Narrow)	53 cm	1 ft 9 in	51 cm	1 ft 8 in	70 cm	2 ft 3.5 in
I J Wall access front/side (Standard)	15/33 cm	6 in/1 ft 1 in	18/43 cm	7 in/1 ft 5 in	20/53 cm	8 in/1 ft 9 in
Wall access front/side (RT/Narrow)	30/43 cm	1 ft/1 ft 5 in	25/43 cm	10 in/1 ft 5 in	23/51 cm	9 in/1 ft 8 in
Outdoor:						
F G Outrigger footprint (l/w) (Standard)	2.46/2.26 m	8 ft 1 in/7 ft 5 in	2.97/2.79 m	9 ft 9 in/9 ft 2 in	2.97/2.79 m	9 ft 9 in/9 ft 2 in
Outrigger footprint (l/w) (RT/Narrow)	_____	_____	_____	_____	_____	_____
H Corner access*** (Standard)	48 cm	1 ft 7 in	76 cm	2 ft 6 in	69 cm	2 ft 3 in
Corner access*** (RT/Narrow)	_____	_____	_____	_____	_____	_____
I J Wall access front/side (Standard)	48/81 cm	1 ft 7 in/2 ft 8 in	74 cm/1.07 m	2 ft 5 in/3 ft 6 in	69 cm/1.07 m	2 ft 3 in/3 ft 6 in
Wall access front/side (RT/Narrow)	_____	_____	_____	_____	_____	_____

Platform Dimensions: (l/w/h)

Standard	69 cm/66 cm/1.14 m	27/26/44.75 in	69 cm/66 cm/1.14 m	27/26/44.75 in	69 cm/66 cm/1.14 m	27/26/44.75 in
Gated standard	69 cm/66 cm/1.14 m	27/26/44.75 in	69 cm/66 cm/1.14 m	27/26/44.75 in	69 cm/66 cm/1.14 m	27/26/44.75 in
Gated narrow	66 cm/51 cm/1.14 m	26/20/44.75 in	66 cm/51 cm/1.14 m	26/20/44.75 in	66 cm/51 cm/1.14 m	26/20/44.75 in
Gated ultra-narrow	56 cm/46 cm/1.14 m	22/18/44.75 in	56 cm/46 cm/1.14 m	22/18/44.75 in	56 cm/46 cm/1.14 m	22/18/44.75 in
Standard fiberglass	74 cm/67 cm/1.10 m	29/26.5/43.5 in	74 cm/67 cm/1.10 m	29/26.5/43.5 in	74 cm/67 cm/1.10 m	29/26.5/43.5 in

Power

Power source - DC models	12V / 110/50-60 Hz or 220/50-60 Hz AC	12V / 110/50-60 Hz or 220/50-60 Hz AC	12V / 110/50-60 Hz or 220/50-60 Hz AC
--------------------------	---------------------------------------	---------------------------------------	---------------------------------------

Sound & Vibration Levels

Sound pressure level (ground workstation)	<70 dBA	<70 dBA	<70 dBA	<70 dBA	<70 dBA	<70 dBA
Sound pressure level (platform workstation)	<70 dBA	<70 dBA	<70 dBA	<70 dBA	<70 dBA	<70 dBA
Vibration	<2.5 m/s ²	<8 ft 2 in/s ²	<2.5 m/s ²	<8 ft 2 in/s ²	<2.5 m/s ²	<8 ft 2 in/s ²

Weight****

AC models (Standard)	307 kg	677 lbs	330 kg	727 lbs	352 kg	777 lbs
AC models (RT/Narrow)	299 kg	660 lbs	315 kg	694 lbs	331 kg	729 lbs
DC models (Standard)	347 kg	766 lbs	371 kg	817 lbs	393 kg	867 lbs
DC models (RT/Narrow)	340 kg	749 lbs	354 kg	780 lbs	371 kg	818 lbs
Air motor (Standard)	_____	_____	_____	_____	352 kg	777 lbs
Air motor (RT/Narrow)	_____	_____	_____	_____	331 kg	729 lbs

Standards Compliance

EU Directives: 2006/42/EC - Machinery (harmonized standard EN280:2013); 2004/108/EC (EMC); 2006/95/EC (LVD)

Aerial Work Platforms

AWP™ Super Series™

Specifications

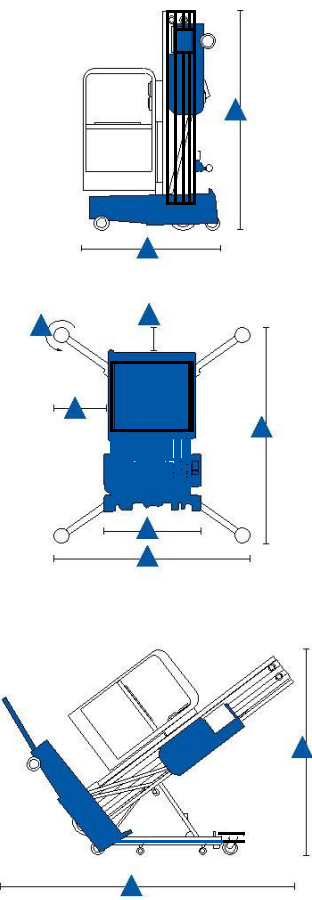

Models	AWP-36S		AWP-40S	
Measurements	Metric	US	Metric	US
Working height*	13.10 m	42 ft 5 in	14.29 m	46 ft 4 in
Platform height	11.10 m	36 ft 5 in	12.29 m	40 ft 4 in
A Height - stowed (Standard)	2.78 m	9 ft 1.5 in	2.78 m	9 ft 1.5 in
B tilted back** (Standard)	1.92 m	6 ft 3.5 in	1.98 m	6 ft 6 in
C Length - stowed (Standard)	1.40 m	4 ft 7 in	1.42 m	4 ft 8 in
D Length - tilted back**	2.97 m	9 ft 9 in	2.97 m	9 ft 9 in
E Width (Standard)	74 cm	2 ft 5 in	74 cm	2 ft 5 in
Width (RT)	—	—	—	—

Productivity

Lift capacity	159 kg	350 lbs	136 kg	300 lbs
Indoor:				
F G Outrigger footprint (l/w) (Standard)	2.12/1.91 m	6 ft 11 in/6 ft 3 in	2.26/2.06 m	7 ft 5 in/6 ft 9 in
H Outrigger footprint (l/w) (RT)	—	—	—	—
I Corner access*** (Standard)	74 cm	2 ft 5 in	79 cm	2 ft 7 in
J Corner access*** (RT)	—	—	—	—
K Wall access front/side (Standard)	36/64 cm	1 ft 2 in/2 ft 1 in	38/71 cm	1 ft 3 in/2 ft 4 in
L Wall access front/side (RT)	—	—	—	—
Outdoor:				
F G Outrigger footprint (l/w) (Standard)	3.53/3.33 m	11 ft 7 in/10 ft 11 in	3.89/3.68 m	12 ft 9 in/12 ft 1 in
H Outrigger footprint (l/w) (RT)	—	—	—	—
I Corner access*** (Standard)	1.02 m	3 ft 4 in	1.12 m	3 ft 8 in
J Corner access*** (RT)	—	—	—	—
K Wall access front/side (Standard)	1.02/1.32 m	3 ft 4 in/4 ft 4 in	1.12/1.52 m	3 ft 8 in/5 ft
L Wall access front/side (RT)	—	—	—	—
Platform Dimensions: (l/w/h)				
Standard	69 cm/66 cm/1.14 m	27/26/44.75 in	69 cm/66 cm/1.14 m	27/26/44.75 in
Gated standard	69 cm/66 cm/1.14 m	27/26/44.75 in	69 cm/66 cm/1.14 m	27/26/44.75 in
Gated narrow	66 cm/51 cm/1.14 m	26/20/44.75 in	66 cm/51 cm/1.14 m	26/20/44.75 in
Gated ultra-narrow	56 cm/46 cm/1.14 m	22/18/44.75 in	56 cm/46 cm/1.14 m	22/18/44.75 in
Standard fiberglass	74 cm/67 cm/1.10 m	29/26.5/43.5 in	74 cm/67 cm/1.10 m	29/26.5/43.5 in

Power

Power source - DC models	12V / 110/50-60 Hz or 220/50-60 Hz AC	12V / 110/50-60 Hz or 220/50-60 Hz AC
--------------------------	---------------------------------------	---------------------------------------

Sound & Vibration Levels

Sound pressure level (ground workstation)	<70 dBA	<70 dBA	<70 dBA	<70 dBA
Sound pressure level (platform workstation)	<70 dBA	<70 dBA	<70 dBA	<70 dBA
Vibration	<2.5 m/s ²	<8 ft 2 in/s ²	<2.5 m/s ²	<8 ft 2 in/s ²

Weight****

AC models (Standard)	461 kg	1,017 lbs	472 kg	1,040 lbs
AC models (RT)	—	—	—	—
DC models (Standard)	502 kg	1,107 lbs	513 kg	1,130 lbs
DC models (RT)	—	—	—	—
Air motor (Standard)	—	—	—	—
Air motor (RT)	—	—	—	—

Standards Compliance

EU Directives: 2006/42/EC - Machinery (harmonized standard EN280:2013); 2004/108/EC (EMC); 2006/95/EC (LVD)

* The metric equivalent of working height adds 2 m to platform height. U.S. adds 6 ft to platform height.
 ** Tilt back height with standard platform. For tilt back height with other platforms, please contact your sales representative.
 *** Corner of platform top rail to corner of wall with ability to rotate leveling jack handle.
 **** Weight will vary depending on options and/or country standards.
 — Not Applicable.



Aerial Work Platforms

AWP™ Super Series™

Specifications

Super Straddle Models	AWP-20S		AWP-25S		AWP-30S	
Measurements	Metric	US	Metric	US	Metric	US
A Height	1.78 m	5 ft 10 in	1.78 m	5 ft 10 in	1.78 m	5 ft 10 in
B Length (adjustable)	2.77 – 3.25 m	9 ft 1 in – 10 ft 8 in	2.77 – 3.25 m	9 ft 1 in – 10 ft 8 in	2.77 – 3.25 m	9 ft 1 in – 10 ft 8 in
C Width	97 cm	3 ft 2 in	97 cm	3 ft 2 in	97 cm	3 ft 2 in
Width with required outriggers	1.75 m	5 ft 9 in	2.05 m	6 ft 9 in	2.31 m	7 ft 7 in
D Wheelbase (adjustable)	2.64 - 3.25 m	8 ft 8 in – 10 ft 8 in	2.64 - 3.25 m	8 ft 8 in – 10 ft 8 in	2.64 - 3.25 m	8 ft 8 in – 10 ft 8 in
E Straddle clearance	1.22 m	4 ft	1.22 m	4 ft	1.22 m	4 ft
F Height to ladder	69 cm	2 ft 3 in	69 cm	2 ft 3 in	69 cm	2 ft 3 in
G Height to fixed wheel	1.02 m	3 ft 4 in	1.02 m	3 ft 4 in	1.02 m	3 ft 4 in
Storage dimensions (l/w/d)	2.03 m/94 cm/61 cm 80/37/24 in		2.03 m/94 cm/61 cm 80/37/24 in		2.03 m/94 cm/61 cm 80/37/24 in	

Weight

263 kg	580 lbs	263 kg	580 lbs	263 kg	580 lbs
--------	---------	--------	---------	--------	---------

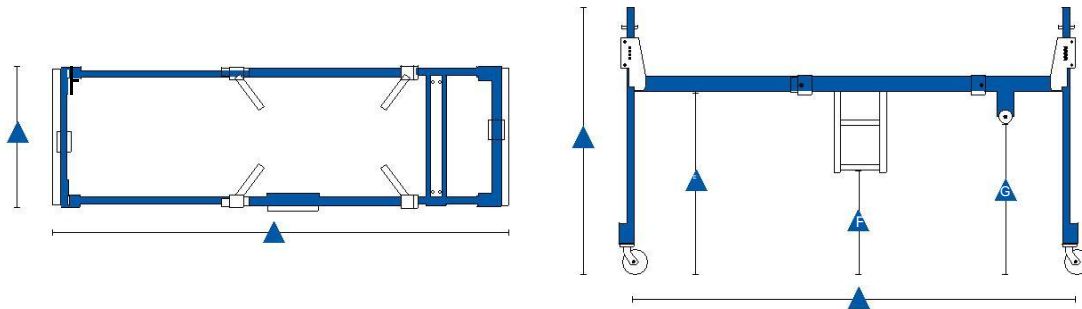

Super Straddle Models	AWP-36S		AWP-40S	
Measurements	Metric	US	Metric	US
A Height	1.78 m	5 ft 10 in	1.78 m	5 ft 10 in
B Length (adjustable)	2.77 – 3.25 m	9 ft 1 in – 10 ft 8 in	2.77 – 3.25 m	9 ft 1 in – 10 ft 8 in
C Width	97 cm	3 ft 2 in	97 cm	3 ft 2 in
Width with required outriggers	2.57 m	8 ft 5 in	2.77 m	9 ft 1 in
D Wheelbase (adjustable)	2.64 - 3.25 m	8 ft 8 in – 10 ft 8 in	2.64 - 3.25 m	8 ft 8 in – 10 ft 8 in
E Straddle clearance	1.22 m	4 ft	1.22 m	4 ft
F Height to ladder	69 cm	2 ft 3 in	69 cm	2 ft 3 in
G Height to fixed wheel	1.02 m	3 ft 4 in	1.02 m	3 ft 4 in
Storage dimensions (l/w/d)	2.03 m/94 cm/61 cm 80/37/24 in		2.03 m/94 cm/61 cm 80/37/24 in	

Weight

263 kg	580 lbs	263 kg	580 lbs
--------	---------	--------	---------



Aerial Work Platforms

AWP™ Super Series™

Features

Standard Features

Measurements

AWP-20S

- 8.12 m (26 ft 1 in) working height
- 6.12 m (20 ft 1 in) platform height
- 74 cm (2 ft 5 in) standard base width
- 76 cm (2 ft 6 in) RT base width
- 56 cm (1 ft 11 in) narrow base width
- Up to 159 kg (350 lbs) lift capacity

AWP-25S

- 9.57 m (30 ft 10 in) working height
- 7.57 m (24 ft 10 in) platform height
- 74 cm (2 ft 5 in) standard base width
- 76 cm (2 ft 6 in) RT base width
- 56 cm (1 ft 11 in) narrow base width
- Up to 159 kg (350 lbs) lift capacity

AWP-30S

- 11 m (35 ft 6 in) working height
- 9 m (29 ft 6 in) platform height
- 74 cm (2 ft 5 in) standard base width
- 76 cm (2 ft 6 in) RT base width
- 56 cm (1 ft 11 in) narrow base width
- Up to 159 kg (350 lbs) lift capacity

AWP-36S

- 13.10 m (42 ft 5 in) working height
- 11.10 m (36 ft 5 in) platform height
- 74 cm (2 ft 5 in) standard base width
- Up to 159 kg (350 lbs) lift capacity

AWP-40S

- 14.29 m (46 ft 4 in) working height
- 12.29 m (40 ft 4 in) platform height
- 74 cm (2 ft 5 in) standard base width
- Up to 136 kg (300 lbs) lift capacity

Productivity

- Auxiliary platform lowering
- Most rigid mast in the industry
- Rocker base system for manoeuvrability
- Tilt back frame (standard on AWP-36, -40)
- Easily rolls through standard doorways
- AC power to platform
- Dual activated up/down switch
- Small outrigger footprints
- Outrigger storage pockets
- Easy loading in pickup trucks
- Tie down attachment points
- Overhead crane attachment point
- Wide forklift pockets
- Rear access forklift pocket
- LED lights confirm proper set-up



⁽¹⁾ Available aftermarket only
⁽²⁾ Factory-fit option only.

Easily Configured To Meet Your Needs

Platform Options

- Sliding mid-rail platform (standard)
- Gated standard platform
- Gated narrow platform
- Gated ultra-narrow platform
- Standard fiberglass platform

Power Options

- AC power 85V / 50-60 Hz
- AC power 110V / 50-60 Hz
- AC power 220V / 50-60 Hz
- DC power with worldwide automatic "smart" charging system (12V / 110V / 230V / 50-60 Hz)
- Air motor power 1.5 hp (1.1 kW) (AWP-30 only) ⁽²⁾

Base Options

- Standard base
- Rough terrain (RT) base (AWP™ -20, -25, -30 only)
- Narrow base (AWP-20, AWP-25, AWP-30 only)

Options & Accessories

Productivity

- Power to platform (plug, socket and ground fault interrupt leakage on request)
- Super-straddle
- Narrow base conversion kit (AWP-20, -25, -30 RT only) ⁽¹⁾
- Different lengths of outriggers (please refer to safety decals for base use in./out. application)
- Outdoor outriggers for AWP Standard base only ⁽¹⁾
- Rough terrain base conversion kit (AWP-20, -25, -30 N only) ⁽¹⁾
- Operational warning light and descent alarm package
- Tool tray (not available on narrow or ultra-narrow platform)
- Fluorescent tube caddy (not available on fiberglass platform)
- Platform locating laser light (not available on fiberglass platform)

Productivity

- Air motor power 1.5 hp (1.1 kW) (AWP-30 only)

07/15 Part No. B109380UK

Distributed By

CHERRY PICKER 
 Ireland's Leading Supplier of Access Platforms



cherrypicker.ie



sales@cherrypicker.ie



353 (1) 835 4788



353 87 255 7755