

Renovated, more comfortable and compact

The **self propelled** machine for safe picking activities to up to 4 metres, with **automatic elevation** and a 24 volt battery.

The new version, made completely of aluminium, **holds more**, and is **more manouverable and ergonomic**.

The picking platform



1

1. The manual remote control allows the regulation of the picking platform, even when loaded, according to the edge of the basket..



2

2. Wide loading platform, extendable up to 66cm x 92cm.

Propelled on the ground, with more compact wheel control for easier picking activities.

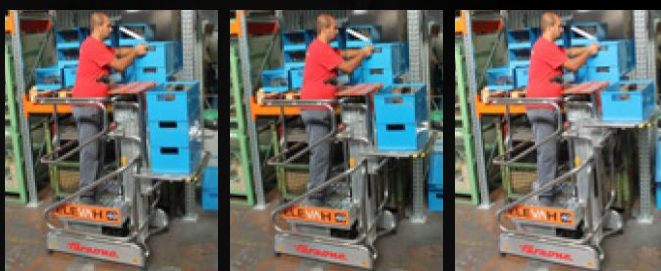

The picking platform is adjustable from the inside.

*** By work cycle we mean a self-propelled movement of 20 m with a full ascent to and descent from the maximum height

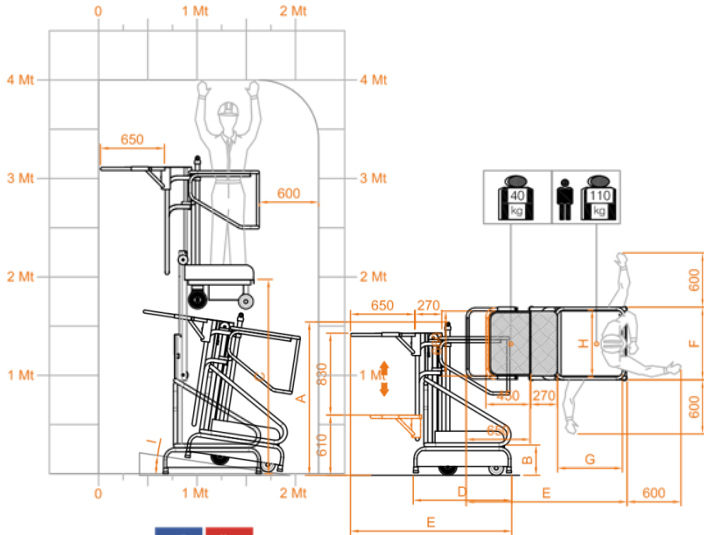

Follow us on



Max capacity		110 + 40 Kg
Number of people		1
Use		internal & external
A	Stowed height	1550 mm
B	Min. height from the ground to the platform level	310 mm
C	Max. height from the ground to the platform level	1960 mm
D	Overall machine dimensions	995 mm
E		1640 mm
F		740 mm
G	Cage inner dimensions	700 mm
H		680 mm
Picking platform		450 mm
		660 mm
Storage tray		270 mm
		660 mm
Picking plate capacity		40 Kg
Machine weight		172 Kg
N° 2 batteries AGM 12 V		33 Ah* - 45 Ah**
Power supply		24 V
Battery charger		110 V - 120 V
I	Maximum climbing ability	15%
Driving steering-wheels dimensions		Ø 190 x 60
Fixed wheels dimensions		Ø 150 x 45
Turning radius		800
Maximum rising speed		0,08 m/s
Maximum descending speed		0,1 m/s
Maximum shifting speed		0,8 m/s - 3 Km/h
Work cycles*** (with fresh batteries)		100 - 150

Distributed By

CHERRY PICKER
Ireland's Leading Supplier of Access Platforms



cherrypicker.ie

sales@cherrypicker.ie



353 (1) 835 4788



353 87 255 7755